



Nordstrom Double DB Double Isolation Plug Valves



Experience In Motion

Table of Contents

Conformance to Standard Specifications	3	Drilling Templates, Flange and Ring Joint Dimensions, and Bolting Data for Steel Flanges	27
Seat Principles	4	ASME Class 150 Steel Flange Standard (ASME B16.5-2003)	27
Why use Flowserve Nordstrom Double DB™ Valves?	5	ASME Class 300 Steel Flange Standard (ASME B16.5-2003)	28
ASME Class 150 – Figure 5345	6	ASME Class 400 Steel Flange Standard (ASME B16.5-2003)	29
ASME Class 300 – Figure 5545	7	ASME Class 600 Steel Flange Standard (ASME B16.5-2003)	30
ASME Class 300 – Figure 5549	8	ASME Class 900 Steel Flange Standard (ASME B16.5-2003)	31
ASME Class 600 – Figure 5645	9	ASME Class 1500 Steel Flange Standard (ASME B16.5-2003)	31
ASME Class 600 – Figure 5649	10	ASME Class 2500 Steel Flange Standard (ASME B16.5-2003)	31
ASME Class 900 – Figure 5749	11	API 6B Flanges for 2000 psi Rated Working Pressure	32
ASME Class 1500 – Figure 5845	12	API 6B Flanges for 3000 psi Rated Working Pressure	32
ASME Class 1500 – Figure 5849	13	API 6B Flanges for 5000 psi Rated Working Pressure	32
ASME Class 1500 – Figure 6845	14	Typical Materials of Construction	33
ASME Class 1500 – Figure 6849	15	Size 4 and Smaller Valves	33
ASME Class 2500 – Figure 5945	16	Size 6 and Larger – Nonpressure Seal Valves	34
ASME Class 2500 – Figure 5949	17	Size 6 and Larger – Pressure Seal Valves	35
ASME Class 2500 – Figure 6945	18		
ASME Class 2500 – Figure 6949	19		
API 5000 – Figure 32049	20		
Carbon Steel Valve Pressure Temperature Ratings	21		
Stainless Steel Valve Pressure Temperature Ratings	22		
Test and Working Pressures (PSIG minimum)	23		
Test Times	23		
Hard-Surfaced Valves	23		
Dynamic Balance Standard Design Categories	24		
NACE Construction Valves for Sour Gas Applications	24		
Dynamic Balance Plug Valve Metals	24		
Actuators for Dynamic Balance Valves	25		
Wrenches, Adapters and Locking Devices	26		

About This Brochure

Every attempt has been made to make the data in this brochure as accurate as possible. Flowserve reserves the right to make product modifications that contradict the contents of this document without notification to its holders. Flowserve cannot be held responsible for data that is found to be inaccurate or incomplete.

Dimensions

Upper dimensions and weights are in inches and pounds.

Lower dimensions and weights are in millimeters and kilograms.

Valve Figure Number Explanation

Valve figure numbers ending in a 9 indicate flanged ends with worm gear operator.

Valve figure numbers ending in a 5 indicate flanged ends with wrench operated stem.

Valve figure numbers ending in ½ indicate welding ends.

Valve figure numbers ending in ¼ indicate one welding end and one flanged end.

Valve figure numbers beginning in 5 indicate that the stems are opposing. Valve figure numbers beginning in 6 indicate that both stems are up.

Dynamic Balance is a registered trademark.

Conformance to Standard Specifications

Wherever applicable, steel plug valves by Flowserve Nordstrom Valves conform to the latest edition of the following standard specifications as to pressure ratings, dimensions and construction. Consult your Flowserve Nordstrom Valves customer service representative for additional information.

ASME – AMERICAN SOCIETY OF MECHANICAL ENGINEERS

- B16.5 Pipe Flanges and Flanged Fittings
- B16.10 Face-to-Face and End-to-End Dimensions of Valves
- B16.25 Butt Welding Ends
- B16.34 Valves – Flanged, Threaded, and Welding End
- B18.2.1 Square and Hex Bolts and Screws
- B18.2.2 Square and Hex Nuts

API – AMERICAN PETROLEUM INSTITUTE

- 6A Specification for Wellhead and Christmas Tree Equipment
- 6D/ISO 14313 Specification for Pipeline Valves
- 6FA Fire Test for Valves
- 599 Steel and Ductile Iron Plug Valves

MSS – MANUFACTURERS STANDARDIZATION SOCIETY OF THE VALVE AND FITTINGS INDUSTRY

- SP-6 Standard Finishes for Contact Faces of Pipe Flanges and Connecting-End Flanges of Valves and Fittings
- SP-25 Standard Marking System for Valves, Fittings, Flanges and Unions
- SP-55 Quality Standard for Steel Castings for Valves, Flanges and Fittings and Other Piping Components — Visual Method for Evaluation of Surface Irregularities

MR0103 Materials Resistant to Sulfide Stress Cracking in Corrosive Petroleum Refining Environments (Valves for NACE Service)

DOT – UNITED STATES DEPARTMENT OF TRANSPORTATION

49 CFR Part 192 Pipeline Safety Regulations (U.S. Department of Transportation)

CAN/CSA Z245.15 Steel Valves

CAN/CSA Z299.3

ISO 9001 CERTIFIED

Seat Principles

Full seat protection, positive shutoff, shearing action and precise fit make the lubricated tapered plug the seat design of choice.

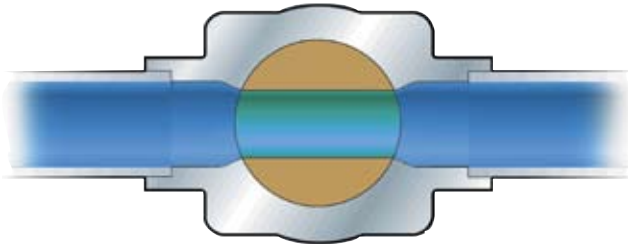

The strength of a tapered plug is its seat design. The tapered metal surfaces of the plug and body are fitted together during manufacture using successive steps of turning, grinding and lapping. The result is a nearly perfectly mated metal-to-metal seating surface.

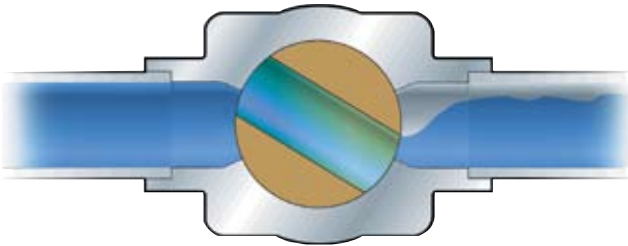

Rotating the plug to close the valve creates a positive shearing action between the body and plug. Tapered plug valves are strong and resilient by design, and are capable of closing through large obstructions. The precisely fitted tapered mated surfaces ensure that the residue is cleaned from the seat each time the valve is closed.

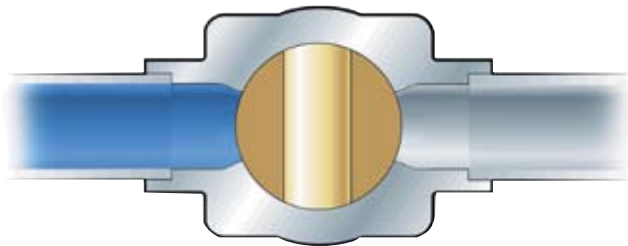

When closed, there is a 15° to 18° overlap between the body and the plug seats on both sides of the flow passage. This provides positive shutoff, even without sealant, and provides bubble-tight shutoff when properly lubricated.

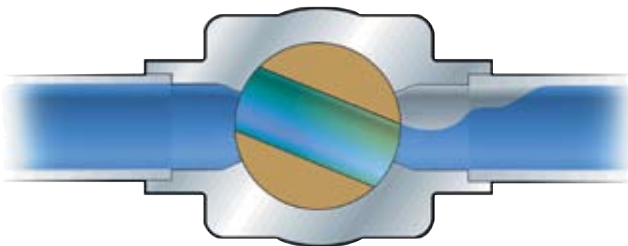

When the valve is opened, metal seats resist erosion from the high-velocity flow through the valve. There are no soft seats to be damaged.

Why use Flowserve Nordstrom Double DB™ Valves?

- Designed for critical shutoff applications where absolute shutoff is required for safety, environmental or process reasons.
 - Compressor isolation
 - Pump isolation
 - Meter isolation
 - Water or gas injection system isolation
 - Critical vents, drains and blow-downs to atmosphere
- Installation and maintenance costs are reduced dramatically.
- Uses proven Dynamic Balance® pressure balance and sealing technology.
- Two superior quality valves with the standard ASME valve dimension of a single valve.
 - Twice as many seats means twice the safety.
 - Allows for maximum port area for better flow.
- Patented technology from the leader in plug valves.*
- Various bleed off connections available such as, Ring Joint, Socket Weld, Threaded, Gate Valves, Needle Valves, etc. Bleed off connections are offered on one side or the other or both.
- Contact the factory for the latest available sizes.
- Flowserve's patented Protected Pressure Balancing ensures that the balancing holes are not exposed to the line media in the plug port, providing added security compared with normal pressure balancing.

*British Patent #2305713B granted in November 1997

Reliable Operation and Exceptional Sealing

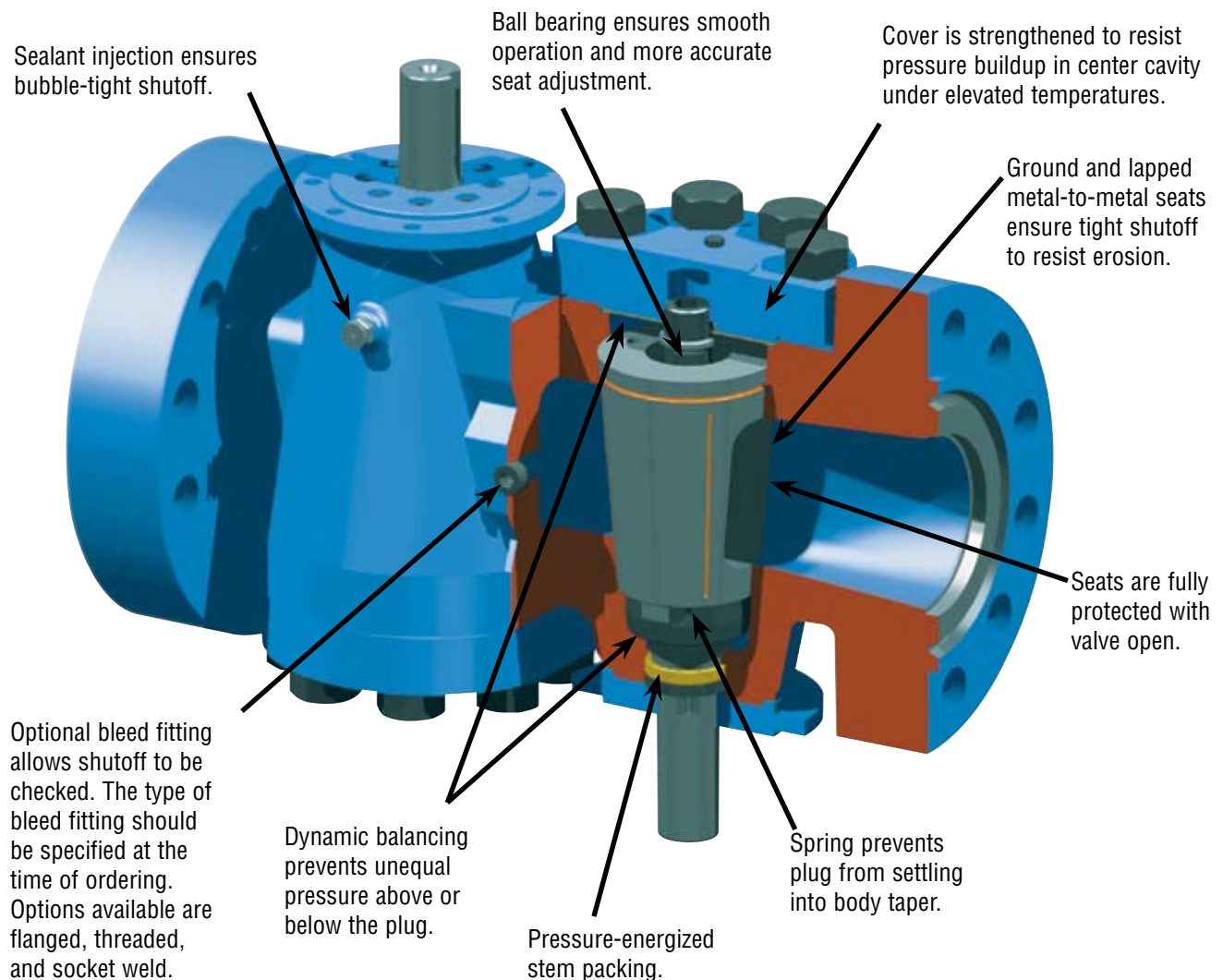

Dynamic Balance Double Isolation Plug Valve

ASME Class 150 (PN 20)

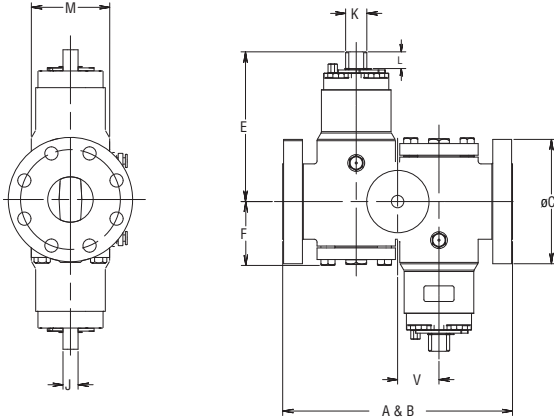

ASME Class 150 – Figure 5345

Size	NPS DN	2 50	6 150
Face-to-Face, flanged (raised face) (incl. 1/16" raised face)	A	11.50* 292	21.50* 546
Face-to-Face, flanged (ring joint)	B	11.62* 295	22.00* 559
Diameter of flange	C	6.00 152	11.00 279
Center to top of stem	E	8.08 205	10.57 268
Center to bottom of body	F	3.79 96	6.44 164
Width of stem flat	J	0.81 21	1.25 32
Diameter of stem	K	1.09 28	1.78 45
Height of stem flat	L	1.00 26	1.10 28
Extreme width of body	M	5.20 132	8.80 224
Centerline of valve to centerline of stem	V	2.17 55	4.00 102
Wrench size	—	DB-2	DB-4
Weight (approx.)	lb. kg	90 41	442 200

Chart current at time of printing. Additional sizes may now be available. Contact Factory for latest available sizes.

*Conforms to API 6D, section 6.3, and is marked accordingly.

Dimensions in inches and millimeters.

Dynamic Balance Double Isolation Plug Valve

ASME Class 300 (PN 50)

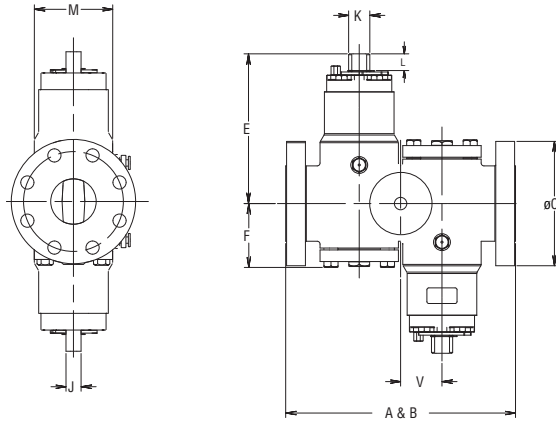

ASME Class 300 – Figure 5545

Size	NPS DN	2 50	3 80
Face-to-Face, flanged (raised face) (incl. 1/8" raised face)	A	11.12* 282	15.25* 387
Face-to-Face, flanged (ring joint)	B	11.75* 298	15.88* 403
Diameter of flange	C	6.50 165	8.25 210
Center to top of stem	E	8.00 203	9.40 239
Center to bottom of body	F	3.40 86	4.20 107
Width of stem flat	J	0.81 21	1.00 25
Diameter of stem	K	1.09 28	1.41 36
Height of stem flat	L	1.20 31	1.30 33
Extreme width of body	M	5.20 132	5.20 132
Centerline of valve to centerline of stem	V	2.17 55	2.74 70
Wrench size	—	DB-2	DB-3
Weight (approx.)	lb. kg	100 46	170 77

Chart current at time of printing. Additional sizes may now be available. Contact Factory for latest available sizes.

*Conforms to API 6D, section 6.3, and is marked accordingly.

Dimensions in inches and millimeters.

Dynamic Balance Double Isolation Plug Valve

ASME Class 300 (PN 50)

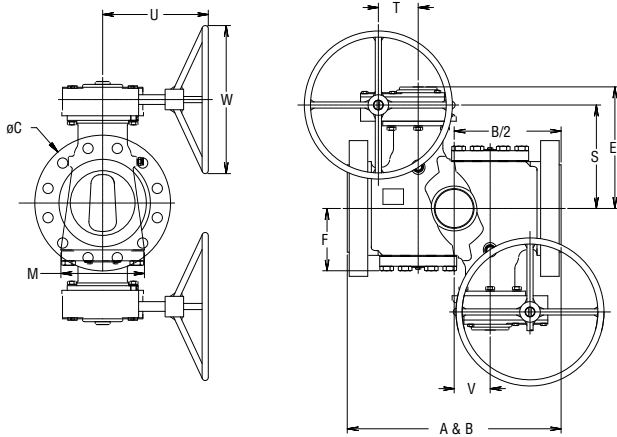

ASME Class 300 – Figure 5549		
Size	NPS DN	6 80
Face-to-Face, flanged (raised face) (incl. 1/16" raised face)	A	27.75 705
Face-to-Face, flanged (ring joint)	B	28.00 711
Diameter of flange	C	12.50 318
Center to bottom of body	F	7.91 201
Extreme width of body	M	10.82 275
Centerline of valve to centerline of gearing	V	4.77 121
Category A and C Gear Dimensions		
Center to top (gearing)	E	12.70 322
Center of port to center of handwheel	S	10.40 264
Longitudinal centerline to handwheel centerline	T	4.80 122
Longitudinal centerline to face of handwheel	U	14.09 358
Handwheel diameter/Number of turns to open gearing	W	24/17 610/17
Weight (approx.)	lb. kg	1020 463
Category B and D Gear Dimensions		
Center to top (gearing)	E	12.70 322
Center of port to center of handwheel	S	10.40 264
Longitudinal centerline to handwheel centerline	T	4.80 122
Longitudinal centerline to face of handwheel	U	14.09 358
Handwheel diameter/Number of turns to open gearing	W	24/17 610/17
Weight (approx.)	lb. kg	1020 463

Chart current at time of printing. Additional sizes may now be available. Contact Factory for latest available sizes.
 For motorization contact factory for correct gear model and valve outline dimensions.
 For Category E, F, H, J and K valve gearing dimensions, contact factory.
 For buried service or offshore applications, contact factory.
 Dimensions in inches and millimeters.

Dynamic Balance Double Isolation Plug Valve

ASME Class 600 (PN 100)

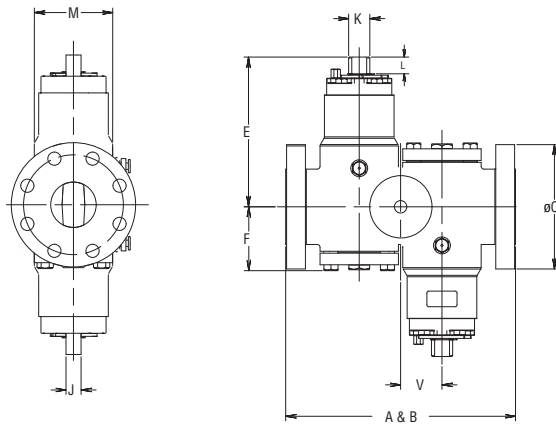

ASME Class 600 – Figure 5645

Size	NPS DN	2 50	3 80
Face-to-Face, flanged (raised face) (incl. ¼" raised face)	A	11.50 292	14.00 356
Face-to-Face, flanged (ring joint)	B	11.62 295	14.12 359
Diameter of flange	C	6.50 165	8.25 210
Center to top of stem	E	8.00 205	9.40 239
Center to bottom of body	F	3.40 86	4.20 107
Width of stem flat	J	0.80 20	1 25
Diameter of stem	K	1.09 27	1.40 35
Height of stem flat	L	1.20 31	1.30 33
Extreme width of body	M	5.20 132	6.80 173
Centerline of valve to centerline of stem	V	2.17 55	2.53 64
Wrench size	—	DB-2	DB-3
Weight (approx.)		lb. kg	100 46
			170 77.3

Chart current at time of printing. Additional sizes may now be available. Contact Factory for latest available sizes.
Dimensions in inches and millimeters.

Dynamic Balance Double Isolation Plug Valve

ASME Class 600 (PN 100)

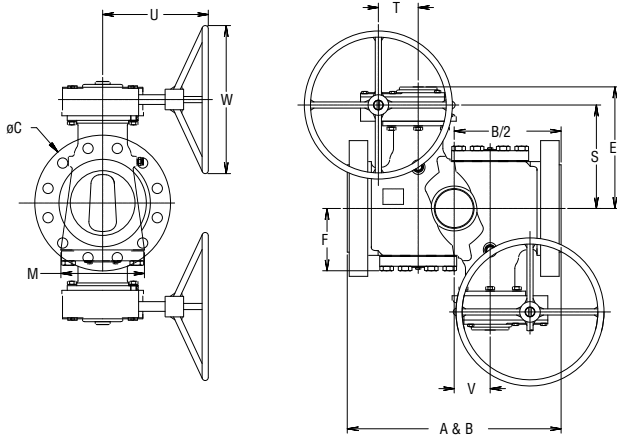

ASME Class 600 – Figure 5649		
Size	NPS DN	8 200
Face-to-Face, flanged (raised face) (incl. 1/4" raised face)	A	26.00 660
Face-to-Face, flanged (ring joint)	B	26.12 663
Diameter of flange	C	16.50 419
Center to bottom of body	F	7.60 193
Extreme width of body	M	10.20 259
Centerline of valve to centerline of gearing	V	4.38 111
Category A and C Gear Dimensions		
Center to top (gearing)	E	14.80 376
Center of port to center of handwheel	S	12.60 320
Longitudinal centerline to handwheel centerline	T	4.84 123
Longitudinal centerline to face of handwheel	U	12.80 325
Handwheel diameter/Number of turns to open gearing	W	18/17 457/17
Weight (approx.)	lb. kg	850 386
Category B and D Gear Dimensions		
Center to top (gearing)	E	14.80 376
Center of port to center of handwheel	S	12.60 320
Longitudinal centerline to handwheel centerline	T	4.84 123
Longitudinal centerline to face of handwheel	U	12.80 325
Handwheel diameter/Number of turns to open gearing	W	18/17 457/17
Weight (approx.)	lb. kg	850 386

Chart current at time of printing. Additional sizes may now be available. Contact Factory for latest available sizes.
 For motorization contact factory for correct gear model and valve outline dimensions.
 For Category E, F, H, J and K valve gearing dimensions, contact factory.
 For buried service or offshore applications, contact factory.
 Dimensions in inches and millimeters.

Dynamic Balance Double Isolation Plug Valve

ASME Class 900 (PN 150)

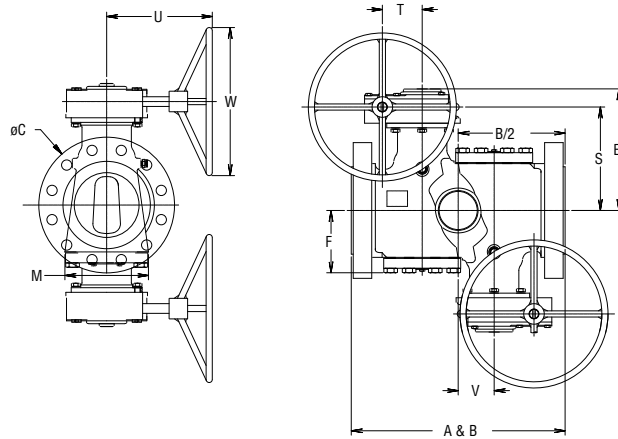

ASME Class 900 – Figure 5749

Size	NPS DN	4 100	6 80	8 200	10 250
Face-to-Face, flanged (raised face) (incl. ¼" raised face)	A	18.00 457	24.00 610	29.00 737	33.00 838
Face-to-Face, flanged (ring joint)	B	18.12 460	24.12 613	29.12 740	33.12 841
Diameter of flange	C	11.50 292	15.00 381	18.50 470	21.50 546
Center to bottom of body	F	6.06 154	7.20 183	10.72 273	11.40 290
Extreme width of body	M	8.70 221	10.00 254	12.80 325	15.60 396
Centerline of valve to centerline of gearing	V	8.70 221	4.45 113	5.59 142	6.24 158
Category A and C Gear Dimensions					
Center to top (gearing)	E	12.12 308	15.50 392	16.30 414	19.90 504
Center of port to center of handwheel	S	10.41 264	13.20 336	13.30 338	16.90 428
Longitudinal centerline to handwheel centerline	T	3.52 89	4.84 123	6.06 154	6.06 154
Longitudinal centerline to face of handwheel	U	10.09 256	14.09 358	15.08 383	16.45 418
Handwheel diameter/Number of turns to open gearing	W	14/15 356/15	24/17 610/17	24/22 610/22	30/22 762/22
Weight (approx.)	lb. kg	460 209	800 363	1580 717	2140 971
Category B and D Gear Dimensions					
Center to top (gearing)	E	12.12 308	15.50 392	16.30 414	20.80 529
Center of port to center of handwheel	S	10.41 264	13.20 336	13.30 338	17.50 444
Longitudinal centerline to handwheel centerline	T	3.52 89	4.84 123	6.06 154	2.10 54
Longitudinal centerline to face of handwheel	U	10.09 256	14.09 358	15.08 383	21.01 534
Handwheel diameter/Number of turns to open gearing	W	14/15 356/15	24/17 610/17	24/22 610/22	30/22 762/45
Weight (approx.)	lb. kg	460 209	800 363	1580 717	2230 1012

Chart current at time of printing. Additional sizes may now be available. Contact Factory for latest available sizes.

For motorization contact factory for correct gear model and valve outline dimensions.

For Category E, F, H, J and K valve gearing dimensions, contact factory.

For buried service or offshore applications, contact factory.

Dimensions in inches and millimeters.

Dynamic Balance Double Isolation Plug Valve

ASME Class 1500 (PN 250)

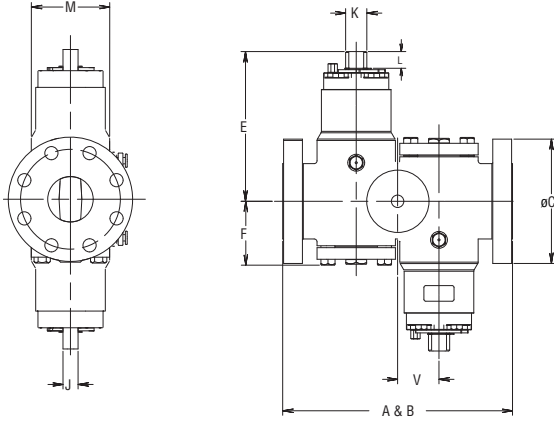

ASME Class 1500 – Figure 5845

Size	NPS DN	2 50	3 80
Face-to-Face, flanged (raised face) (incl. ¼" raised face)	A	14.50 368	18.50 470
Face-to-Face, flanged (ring joint)	B	14.62 371	18.62 473
Diameter of flange	C	8.50 216	10.50 267
Center to top of stem	E	8.10 206	10.20 260
Center to bottom of body	F	4.50 107	5.00 127
Width of stem flat	J	0.81 21	1.00 25
Diameter of stem	K	1.09 28	1.41 36
Height of stem flat	L	1.00 26	1.12 29
Extreme width of body	M	4.70 119	6.20 157
Centerline of valve to centerline of stem	V	2.35 60	3.71 94
Wrench size	—	DB-2	DB-3
Weight (approx.)	lb. kg	140 63	250 114

Chart current at time of printing. Additional sizes may now be available. Contact Factory for latest available sizes.
Dimensions in inches and millimeters.

Dynamic Balance Double Isolation Plug Valve

ASME Class 1500 (PN 250)

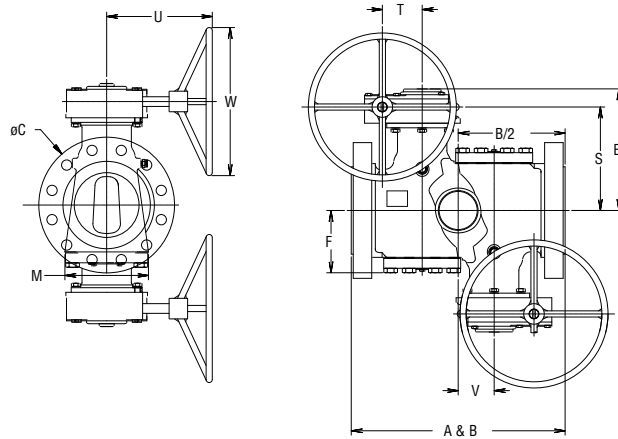

ASME Class 1500 – Figure 5849

Size	NPS DN	2 50	3 80	6 150	10 250	12 300
Face-to-Face, flanged (raised face) (incl. 1/4" raised face)	A	14.50 368	18.50 470	27.75 705	39.00 991	44.50 1130
Face-to-Face, flanged (ring joint)	B	14.62 371	18.62 473	28.00 711	39.38 1000	45.12 1146
Diameter of flange	C	8.50 216	10.50 267	15.50 394	23.00 584	26.50 673
Center to bottom of body	F	4.50 114	5.00 127	7.90 201	12.90 327	14.30 363
Extreme width of body	M	4.70 119	6.20 157	10.82 275	15.88 403	22.00 559
Centerline of valve to centerline of gearing	V	2.35 60	3.71 94	4.77 121	6.40 162	7.63 194
Category A and C Gear Dimensions						
Center to top (gearing)	E	9.10 231	19.70 500	12.70 322	25.90 658	30.20 767
Center of port to center of handwheel	S	8.14 207	18.20 462	10.40 265	19.70 500	23.00 584
Longitudinal centerline to handwheel centerline	T	2.05 52	2.60 67	4.80 123	8.20 208	8.20 208
Longitudinal centerline to face of handwheel	U	6.90 176	9.40 239	14.10 358	15.30 389	14.90 376
Handwheel diameter/Number of turns to open gearing	W	10/10 254/10	12/10.5 305/10.5	24/17 610/17	24/180 610/180	30/62.5 762/62.5
Weight (approx.)	lb. kg	145 66	288 131	1346 611	3800 2041	4900 2227
Category B and D Gear Dimensions						
Center to top (gearing)	E	9.10 231	19.70 500	12.70 322	25.90 658	30.20 767
Center of port to center of handwheel	S	8.14 207	18.20 462	10.40 265	19.70 500	23.00 584
Longitudinal centerline to handwheel centerline	T	2.05 52	2.60 67	4.80 123	8.20 208	8.20 208
Longitudinal centerline to face of handwheel	U	6.90 176	9.40 239	14.10 358	15.30 389	14.90 376
Handwheel diameter/Number of turns to open gearing	W	10/10 254/10	14/10.5 356/10.5	24/17 610/17	24/180 610/180	24/180 610/180
Weight (approx.)	lb. kg	145 66	288 131	1346 611	3800 2041	4900 2227

Chart current at time of printing. Additional sizes may now be available. Contact Factory for latest available sizes.

For motorization contact factory for correct gear model and valve outline dimensions.

For Category E, F, H, J and K valve gearing dimensions, contact factory.

For buried service or offshore applications, contact factory.

Dimensions in inches and millimeters.

Dynamic Balance Double Isolation Plug Valve

ASME Class 1500 (PN 250)

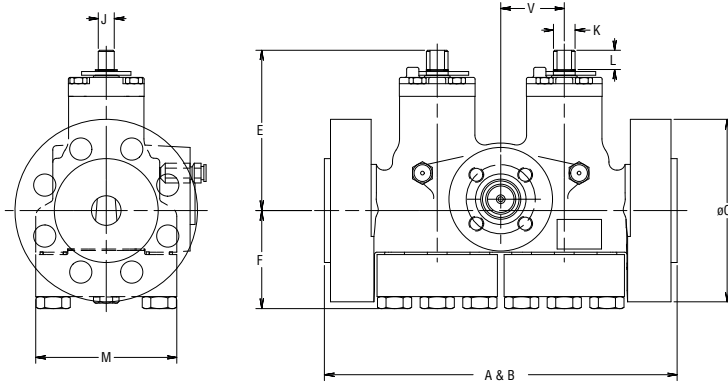

ASME Class 1500 – Figure 6845				
Size	NPS DN	2 50	3 75	4 100
Face-to-Face, flanged (raised face) (incl. 1/16" raised face)	A	14.50 368	18.50 470	21.50 546
Face-to-Face, flanged (ring joint)	B	14.62 371	18.62 473	21.62 549
Diameter of flange	C	8.50 216	10.50 267	12.25 311
Center to top of stem	E	6.60 168	9.98 254	10.09 256
Center to bottom of body	F	4.20 107	5.19 132	5.80 147
Width of stem flat	J	0.81 21	1.00 25	1.25 32
Diameter of stem	K	1.09 28	1.41 36	1.78 45
Height of stem flat	L	1.00 26	1.10 28	1.20 29
Extreme width of body	M	6.98 177	6.20 158	9.12 232
Centerline of valve to centerline of stem	V	2.75 70	3.71 94	3.74 95
Wrench size	—	DB-2	DB-2	DB-4
Weight (approx.)	lb. kg	150 68	310 141	480 218

Chart current at time of printing. Additional sizes may now be available. Contact Factory for latest available sizes. Dimensions in inches and millimeters.

Dynamic Balance Double Isolation Plug Valve

ASME Class 1500 (PN 250)

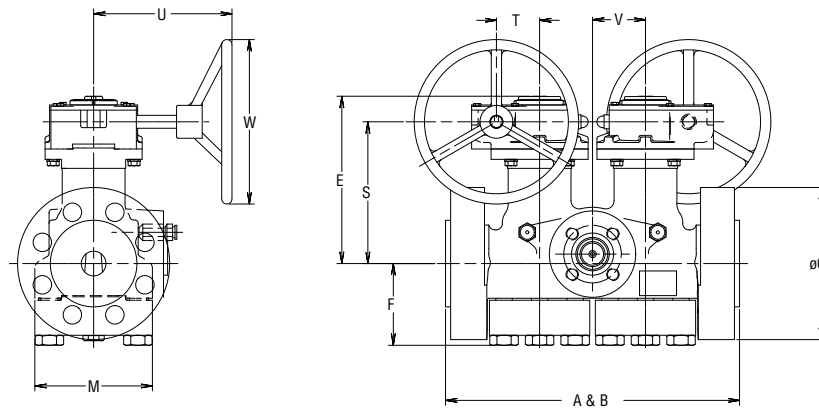

ASME Class 1500 – Figure 6849				
Size	NPS DN	2 50	4 100	6 150
Face-to-Face, flanged (raised face) (incl. 1/16" raised face)	A	14.50 368	21.50 546	27.75 705
Face-to-Face, flanged (ring joint)	B	14.62 371	21.62 549	28.00 712
Diameter of flange	C	8.50 216	12.25 311	15.50 394
Center to bottom of body	F	4.20 107	5.8 147	7.90 201
Extreme width of body	M	6.98 177	9.12 232	10.80 25.4
Centerline of valve to centerline of gearing	V	2.75 70	3.74 95	10.40 264
Category A and C Gear Dimensions				
Center to top (gearing)	E	7.70 196	13.40/11.90* 340/302	13.40 340
Center of port to center of handwheel	S	6.50 164	11.60/10.10* 295/256	11.20 285
Longitudinal centerline to handwheel centerline	T	2.10 52	3.40 86	4.80 122
Longitudinal centerline to face of handwheel	U	7.13 181	10.19 259	14.10 358
Handwheel diameter/Number of turns to open gearing	W	10/10 254/10	18/11.5 457/11.5	24 610
Weight (approx.)	lb. kg	175 79	590 268	1040 472
Category B and D Gear Dimensions				
Center to top (gearing)	E	7.70 196	13.40/11.90* 340/302	13.40 340
Center of port to center of handwheel	S	6.50 164	11.60/10.10* 295/256	11.20 285
Longitudinal centerline to handwheel centerline	T	2.10 52	3.40 86	4.80 122
Longitudinal centerline to face of handwheel	U	7.13 181	10.19 259	14.10 358
Handwheel diameter/Number of turns to open gearing	W	10/10 254/10	18/11.5 457/11.5	24/17 610/17
Weight (approx.)	lb. kg	175 79	590 268	1040 472

Chart current at time of printing. Additional sizes may now be available. Contact Factory for latest available sizes.

* Note: Gearbox height is offset between center sections.

For motorization contact factory for correct gear model and valve outline dimensions.

For Category E, F, H, J and K valve gearing dimensions, contact factory.

For buried service or offshore applications, contact factory.

Dimensions in inches and millimeters.

Dynamic Balance Double Isolation Plug Valve

ASME Class 2500 (PN 420)

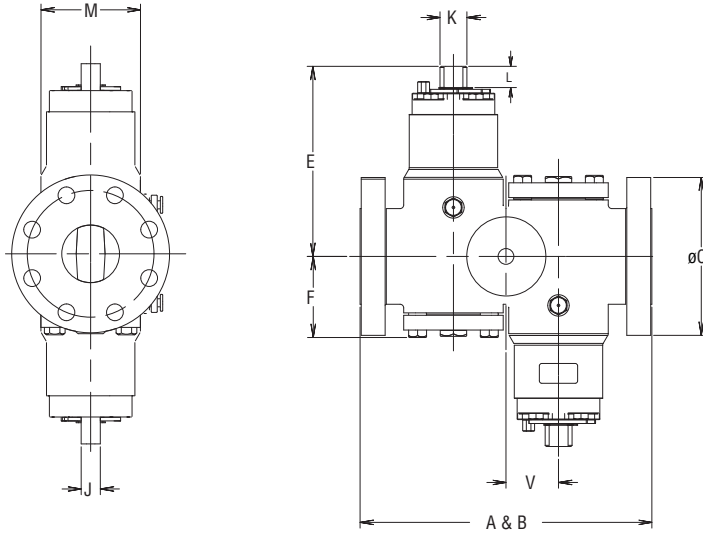

ASME Class 2500 – Figure 5945

Size	NPS DN	2 50	3 80
Face-to-Face, flanged (raised face) (incl. ¼" raised face)	A	17.75 451	22.75 578
Face-to-Face, flanged (ring joint)	B	17.88 454	23.00 584
Diameter of flange	C	9.25 235	12.00 305
Center to top of stem	E	8.12 206	8.54 217
Center to bottom of body	F	5.16 131	5.83 148
Width of stem flat	J	0.81 21	1.00 25
Diameter of stem	K	1.09 28	1.41 36
Height of stem flat	L	1.00 26	1.10 28
Extreme width of body	M	7.20 183	8.60 218
Centerline of valve to centerline of stem	V	3.22 82	4.15 105
Wrench size	—	DB-2	DB-3
Weight (approx.)	lb. kg	270 122	560 254

Chart current at time of printing. Additional sizes may now be available. Contact Factory for latest available sizes.
Dimensions in inches and millimeters.

Dynamic Balance Double Isolation Plug Valve

ASME Class 2500 (PN 420)

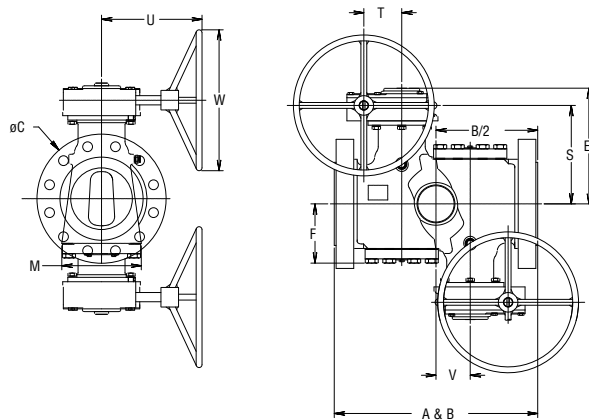

ASME Class 2500 – Figure 5949

Size	NPS DN	2 50	3 80	4 100	6 150	8 200	10 250	12 300
Face-to-Face, flanged (raised face) (incl. ¼" raised face)	A	17.75	22.88	26.76	36.38	40.25	50.76	56.00
		451	281	680	924	1022	1289	1422
Face-to-Face, flanged (ring joint)	B	17.88	23.00	26.88	36.50	40.88	50.88	56.88
		454	584	683	927	1038	1292	1445
Diameter of flange	C	9.25	12.00	14.00	19.00	21.75	26.50	30.00
Center to bottom of body	F	5.00	5.70	6.70	9.60	11.80	13.50	17.84
		127	145	170	244	300	343	453
Extreme width of body	M	7.20	8.60	10.00	14.00	17.80	23.10	28.50
		183	218	254	356	452	587	724
Centerline of valve to centerline of gearing	V	3.22	4.15	4.90	5.00	7.00	7.38	7.72
		82	105	124	127	178	187	196
Category A and C Gear Dimensions								
Center to top (gearing)	E	11.30	10.90	11.10	16.30	20.70	29.10	31.75
		287	277	282	414	526	740	806
Traverse centerline to handwheel centerline	P							13.50
								343
Center to top of handwheel	Q							50.03
								1271
Center of port to center of handwheel	S	9.80	9.20	9.40	13.20	15.80	21.70	27.72
		249	234	238	335	401	550	704
Longitudinal centerline to handwheel centerline	T	2.60	3.50	3.50	6.10	3.81	9.30	11.50
		66	89	90	155	97	237	292
Longitudinal centerline to face of handwheel	U	9.40	9.47	11.52	15.10	20.80	25.60	27.12
		239	240	293	384	528	651	689
Handwheel diameter/Number of turns to open gearing	W	10/10.5	12/15	24/15	24/22	24/62.5	30/135	30/150
		254/10.5	305/15	610/15	610/22	610/62.5	762/135	762/150
Weight (approx.)	lb.	290	485	747	1910	3122	6120	10568
	kg	132	220	339	866	1416	2776	4794
Category B and D Gear Dimensions								
Center to top (gearing)	E	11.30	10.90	11.80	16.30	20.70	29.10	31.75
		287	277	300	414	526	740	806
Traverse centerline to handwheel centerline	P							13.50
								343
Center to top of handwheel	Q							50.03
								1271
Center of port to center of handwheel	S	9.80	9.20	9.60	13.20	15.80	21.70	27.72
		249	234	244	335	401	550	704
Longitudinal centerline to handwheel centerline	T	2.60	3.50	4.80	6.10	3.81	9.30	11.50
		66	89	122	155	97	237	292
Longitudinal centerline to face of handwheel	U	9.40	9.47	14.09	15.10	20.80	25.60	21.12
		239	240	358	384	528	651	689
Handwheel diameter/Number of turns to open gearing	W	10/10.5	12/15	24/17	24/22	24/62.5	30/135	30/150
		254/10.5	305/15	610/17	610/22	610/62.5	762/135	762/150
Weight (approx.)	lb.	290	485	800	1910	3122	6120	10568
	kg	132	220	363	866	1416	2776	4794

Chart current at time of printing. Additional sizes may now be available. Contact Factory for latest available sizes.

For motorization contact factory for correct gear model and valve outline dimensions.

For Category E, F, H, J and K valve gearing dimensions, contact factory.

For buried service or offshore applications, contact factory.

Dimensions in inches and millimeters.

Dynamic Balance Double Isolation Plug Valve

ASME Class 2500 (PN 420)

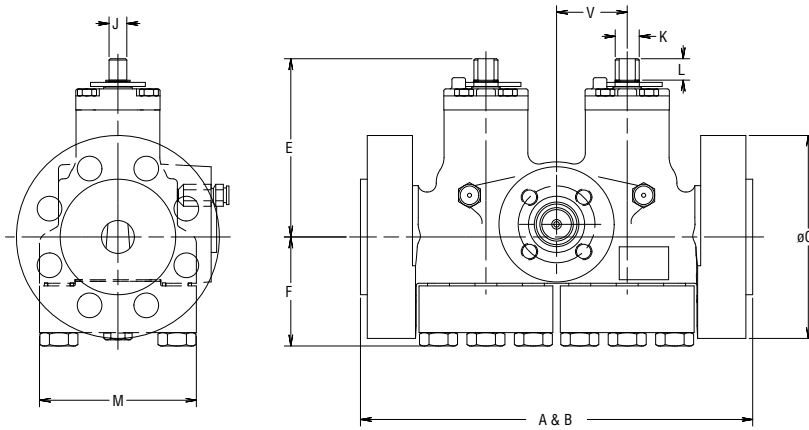

ASME Class 2500 – Figure 6945

Size	NPS DN	2 50	3 80	4 100
Face-to-Face, flanged (raised face) (incl. 1/16" raised face)	A	17.75 451	22.75 578	26.50 673
Face-to-Face, flanged (ring joint)	B	17.88 454	23.00 584	26.88 683
Diameter of flange	C	9.25 235	12.00 305	14.00 356
Center to top of stem	E	8.12 206	8.54 217	10.35 263
Center to bottom of body	F	5.16 131	5.83 148	6.80 173
Width of stem flat	J	0.81 21	1.00 25	1.25 32
Diameter of stem	K	1.09 28	1.41 36	1.78 45
Height of stem flat	L	1.00 26	1.10 28	1.20 29
Extreme width of body	M	7.15 182	8.60 218	10.24 260
Centerline of valve to centerline of stem	V	3.22 82	4.15 105	4.90 124
Wrench size	—	DB-2	DB-3	DB-4
Weight (approx.)		lb. 310 kg 141	500 227	710 322

Chart current at time of printing. Additional sizes may now be available. Contact Factory for latest available sizes.
Dimensions in inches and millimeters.

Dynamic Balance Double Isolation Plug Valve

ASME Class 2500 (PN 420)

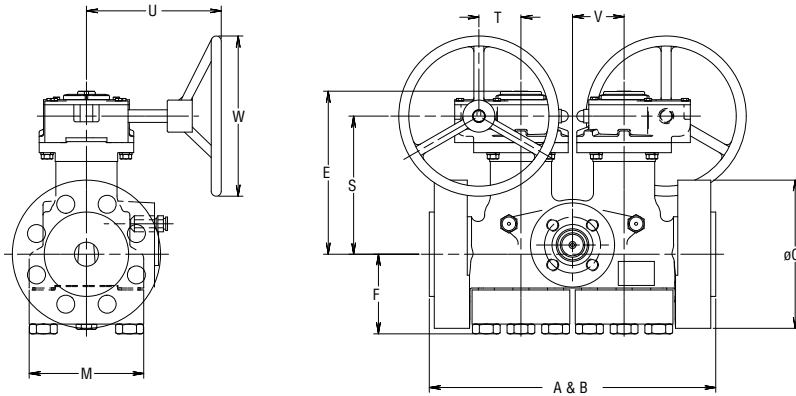

ASME Class 2500 – Figure 6949				
Size	NPS DN	2 50	3 80	4 100
Face-to-Face, flanged (raised face) (incl. 1/16" raised face)	A	17.75	22.75	26.50
		451	578	673
Face-to-Face, flanged (ring joint)	B	17.88	23.00	26.88
		454	584	683
Diameter of flange	C	9.25	12.00	14.00
		235	305	356
Center to bottom of body	F	5.16	5.83	6.8
		131	148	173
Extreme width of body	M	7.15	8.60	10.24
		182	218	260
Centerline of valve to centerline of gearing	V	3.22	4.15	4.9
		82	105	124
Category A and C Gear Dimensions				
Center to top (gearing)	E	10.18	10.94	12.60
		259	278	320
Center of port to center of handwheel	S	8.62	9.21	10.90
		219	234	277
Longitudinal centerline to handwheel centerline	T	2.62	3.52	3.50
		66	89	89
Longitudinal centerline to face of handwheel	U	8.41	9.47	11.52
		214	240	293
Handwheel diameter/Number of turns to open gearing	W	10/10.5	12/15	24/15
		254/10.5	305/15	610/15
Weight (approx.)	lb.	310	500	790
	kg	141	227	358
Category B and D Gear Dimensions				
Center to top (gearing)	E	10.18	10.94	12.60
		259	278	320
Center of port to center of handwheel	S	8.62	9.21	10.90
		219	234	277
Longitudinal centerline to handwheel centerline	T	2.62	3.52	3.50
		66	89	89
Longitudinal centerline to face of handwheel	U	8.41	9.47	11.52
		214	240	293
Handwheel diameter/Number of turns to open gearing	W	10/10.5	12/15	24/15
		254/10.5	305/15	610/15
Weight (approx.)	lb.	310	500	790
	kg	141	227	358

Chart current at time of printing. Additional sizes may now be available. Contact Factory for latest available sizes.

For motorization contact factory for correct gear model and valve outline dimensions.

For Category E, F, H, J and K valve gearing dimensions, contact factory.

For buried service or offshore applications, contact factory.

Dimensions in inches and millimeters.

Dynamic Balance Double Isolation Plug Valve

API 5000

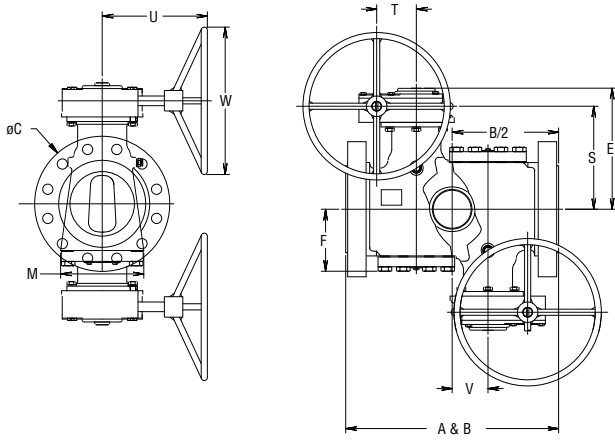

API 5000 – Figure 32049		
Size	NPS	4 1/16
Face-to-Face, flanged (including flat faced ring joint)	B	21.62 549
Diameter of flange	C	12.25 311
Center to bottom of body	F	5.70 145
Extreme width of body	M	8.72 221
Centerline of valve to centerline of gearing	V	3.74 95
Category A and C Gear Dimensions		
Center to top (gearing)	E	12.60 319
Center of port to center of handwheel	S	10.90 276
Longitudinal centerline to handwheel centerline	T	3.50 89
Longitudinal centerline to face of handwheel	U	11.53 293
Handwheel diameter/Number of turns to open gearing	W	24/15 610/15
Weight (approx.)	lb. kg	580 263
Category B and D Gear Dimensions		
Center to top (gearing)	E	13.10 332
Center of port to center of handwheel	S	10.90 276
Longitudinal centerline to handwheel centerline	T	4.80 122
Longitudinal centerline to face of handwheel	U	14.10 358
Handwheel diameter/Number of turns to open gearing	W	24/17 610/17
Weight (approx.)	lb. kg	580 263

Chart current at time of printing. Additional sizes may now be available. Contact Factory for latest available sizes.

For motorization contact factory for correct gear model and valve outline dimensions.

For Category E, F, H, J and K valve gearing dimensions, contact factory.

For buried service or offshore applications, contact factory.

Dimensions in inches and millimeters.

Carbon Steel Valve Pressure Temperature Ratings

Pressure Temperature Ratings (Carbon Steel - ASTM A352 Grade LCC and ASTM A216 Grade WCC)

Working Pressure by Classes (psig)						
Service Temp °F	150	300	600	900	1500	2500
-20 to 100	290	750	1500	2250	3750	6250
200	260	750	1500	2250	3750	6250
250	245	740	1478	2218	3695	6160
300	230	730	1455	2185	3640	6070
400	200	705	1410	2115	3530	5880
450	185	685	1370	2055	3428	5710
500	170	665	1330	1995	3325	5540
600	140	605	1210	1815	3025	5040
700	110	570	1135	1705	2840	4730
750	95	505	1010	1510	2520	4200
800	80	410	825	1235	2060	3430

Working Pressure by Rating Number (bar)						
Service Temp °C	PN20	PN50	PN100	PN150	PN250	PN420
-29 to 38	20.0	51.7	103.4	155.1	258.6	430.9
50	19.0	51.7	103.4	155.1	258.6	430.9
100	17.9	51.7	103.4	155.1	258.6	430.9
120	16.9	51.0	101.9	152.9	254.8	424.7
150	15.9	50.3	100.3	150.7	251.0	418.5
200	13.8	48.6	97.2	145.8	243.4	405.4
232	12.8	47.2	94.5	141.7	236.4	393.7
250	11.7	45.9	91.7	137.6	229.3	382.0
300	9.7	41.7	83.4	125.1	208.6	347.5
350	8.7	40.5	80.9	121.4	202.2	336.8
375	7.6	39.3	78.3	117.6	195.8	326.1
400	6.6	34.8	69.6	104.1	173.7	289.6
425	5.5	28.3	56.9	85.2	142.0	236.5
450	4.7	20.5	41.4	60.1	100.2	166.9

CAN / CSA Z245-15 Ratings

Service Temperature	Working Pressure by Rating Number (kPa)					
	PN20	PN50	PN100	PN150	PN250	PN420
-29 to 120	19.00	49.60	99.30	148.90	248.20	413.70

Maximum Operating Temperatures

Dynamic Balance Plug Valves

Standard construction Dynamic Balance valves (Category A) are suitable for operation at the pressures and temperatures listed in the above table up to a maximum temperature of +450°F (+232°C). Special constructions are available for higher temperatures. Please refer to the design categories section of this brochure. Specific recommendations are available from your customer service representative.

Stainless Steel Valve Pressure Temperature Ratings

Pressure Temperature Ratings (Stainless Steel - ASTM A351 Grade CF8M)

Working Pressure by Classes (psig)						
Service Temp °F	150	300	600	900	1500	2500
-50 to 100	275	720	1440	2160	3600	6000
200	230	600	1200	1800	3000	5000
250	218	570	1140	1710	2850	4750
300	205	540	1080	1620	2700	4500
400	190	495	995	1490	2485	4140
450	180	480	963	1443	2408	4010
500	170	465	930	1395	2330	3880
600	140	435	875	1310	2185	3640
650	125	430	860	1290	2150	3580
700	110	425	850	1275	2125	3540
750	95	415	830	1245	2075	3460
800	80	405	805	1210	2015	3360
850	65	395	790	1190	1980	3000
900	50	390	780	1165	1945	3240
950	35	380	765	1145	1910	3180
1000	20	320	640	965	1605	2675
1050	20 ⁽¹⁾	310	615	925	1545	2570
1100	20 ⁽¹⁾	255	515	770	1285	2145
1150	20 ⁽¹⁾	200	400	595	995	1655
1200	20 ⁽¹⁾	155	310	465	770	1285
1250	20 ⁽¹⁾	115	225	340	565	945
1300	20 ⁽¹⁾	85	170	255	430	715
1350	20 ⁽¹⁾	60	125	185	310	515
1400	20 ⁽¹⁾	50	95	142	240	400
1450	15 ⁽¹⁾	35	70	105	170	285
1500	10 ⁽¹⁾	25	55	80	135	230

Working Pressure Rating by Number (bar)						
Service Temp °C	PN20	PN50	PN100	PN150	PN250	PN420
-45 to 38	19.0	49.6	99.3	148.9	248.2	413.7
50	17.5	45.5	91.0	136.5	227.5	379.2
100	15.9	41.4	82.7	124.1	206.8	344.7
120	15.0	39.3	78.6	117.9	196.5	327.5
150	14.1	37.2	74.5	111.7	186.2	310.3
200	13.1	34.1	68.6	102.7	171.3	285.4
232	12.4	33.1	66.4	99.5	166.0	276.5
250	11.7	32.1	64.1	96.2	160.6	267.5
300	9.7	30.0	60.3	90.3	150.7	251.0
350	8.6	29.6	59.3	88.9	148.2	246.8
375	7.6	29.3	58.6	87.9	146.5	244.1
400	6.6	28.6	57.2	85.8	143.1	238.6
425	5.5	27.9	55.5	83.4	138.9	231.7
450	4.5	27.2	54.5	82.1	136.5	206.8
475	3.4	26.9	53.8	80.3	134.1	223.4
500	2.4	26.2	52.7	78.9	131.7	219.3
525	1.4	22.1	44.1	66.5	110.7	184.4
550	1.3 ⁽¹⁾	21.4	42.4	63.8	106.5	177.2
575	1.3 ⁽¹⁾	19.5	39.0	58.5	97.6	162.6
600	1.3 ⁽¹⁾	17.6	35.5	53.1	88.6	147.9
625	1.3 ⁽¹⁾	13.8	27.6	41.0	68.6	114.1
650	1.3 ⁽¹⁾	10.7	21.4	32.1	53.1	88.6
675	1.3 ⁽¹⁾	7.9	15.5	23.4	39.0	65.2
700	1.3 ⁽¹⁾	5.9	11.7	17.6	29.6	49.3
725	1.3 ⁽¹⁾	4.1	8.6	12.8	21.4	35.5
750	1.3 ⁽¹⁾	3.4	6.6	9.8	16.5	27.6
775	1.0 ⁽¹⁾	2.4	4.8	7.2	11.7	19.7
800	0.7 ⁽¹⁾	1.7	3.8	5.5	9.3	15.9

(1) For welding end valves only. Flanged end ratings terminate at +1,000°F (+540°C).

Test and Working Pressures (PSIG minimum)

(Carbon Steel - ASTM A352 Grade LCC and ASTM A216 Grade WCC)

	ASME Class Valves						API Valves
	150	300	600	900	1500	2500	5000
Maximum Cold Working Pressure	290	750	1500	2250	3750	6250	5000
Hydrostatic Body (Shell) Test	450	1125	2250	3375	5625	9375	10000
Hydrostatic Seat Test	325	825	1650	2475	4125	6875	5000

*Hydrostatic body and seat tests performed on API 6A valves are for 3 minutes each with the hydrostatic body test being performed twice.
Hydrostatic body and seat tests for hard-surfaced valves will be performed at the valve maximum operating pressure for the time periods specified above*

Test Times

Valve Size	Shell Hydrostatic Time, Minutes	Seat Hydrostatic Time, Minutes
4' & Smaller	2	2
6-10	5	5
12-18	15	5
20 and larger	30	5

Hard-Surfaced Valves

For high temperature and abrasive services, Dynamic Balance valves can be supplied with plug taper and body seat hard-surfaced with nickel or cobalt base alloys (Standard Design Categories E, F and K). These materials provide a protective coating having a low coefficient of friction for easier operation at elevated temperatures. With additional hard-surfacing in high erosion areas, hard-surfaced Dynamic Balance valves provide excellent resistance to abrasion in coal, limestone, iron ore, copper ore and other water-carried slurries. For severe services, hard-surfacing extends valve life and improves valve performance significantly.



Flowserve Nordstrom Valves has extensive experience in applying hard-surfacing materials. Special vacuum furnaces keep the base metal of the plug in a controlled, heated atmosphere where the coating alloy can be fused to base metal with optimum adherence. Fully trained technicians take the hard-surfaced plugs and lap these into the matching bodies. Valve assembly at room temperature is made with dimension allowances to assure proper operation at elevated temperatures in actual services. A valve shell test is performed to prove pressure containment, and a seat test is performed with normal adjustment to prove the integrity of the seat. To prevent stress cracking of the hard-surfacing material, these tests are performed at the valve maximum operating pressure.

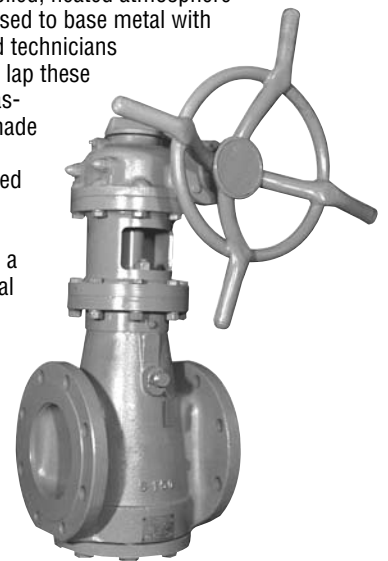

Dynamic Balance Standard Design Categories

In the interests of clarity, Flowserve Nordstrom Valves has designated the following standard design categories for Dynamic Balance valves. When ordering, please indicate the letter suffix that best defines your requirements, along with complete service details.

These categories do not apply to all Dynamic Balance valves in this catalog. Contact your customer service representative for assistance.

- A** The standard carbon steel API-6D and B16.34 valve suitable for general service at temperatures from -20°F to +450°F (-29°C to +232°C). The standard API-6A valve, API Type 2 material, suitable for general API-6A service from 0°F to +250°F (-17°C to +121°C).

NOTE: API 6A valves are available only in NACE offshore construction.

- B** Low temperature valves (LCC material) suitable for general service from -50°F to +450°F (-46°C to +232°C).
- C** Sour gas valves conforming to NACE MR0175, API-6D and B16.34, suitable for -20°F to +450°F (-29°C to +232°C) in accordance with the appropriate standard.
- D** Sour gas valves conforming to NACE MR0175, API-6D and B16.34, constructed of material suitable for low-temperature service -50°F to either +250°F or +450°F (-46°C to +121°C or +232°C), in accordance with the appropriate standard.
- E** Valves suitable for abrasive service from -20°F to +450°F (-29°C to +232°C), essentially carbon steel material with hard-surfaced body and plug.
- F** Valves suitable for moderately high temperatures, +450°F to +800°F (+232°C to +427°C), essentially carbon steel material with hard-surfaced body and plug. Hot tested. Elevated gearing.
- H** Corrosion-resistant valves, wetted parts essentially 316 stainless steel except 17-4 PH drive train, suitable at service temperatures from -50°F to +450°F (-45°C to +232°C).
- J** Corrosion-resistant valves, wetted parts essentially 316 stainless steel except 17-4 PH drive train, suitable at service temperatures for +450°F to +700°F (+232°C to +371°C). Hot tested. Elevated gearing.
- K** Valves suitable for corrosion resistance and high temperature. Parts essentially 316 stainless steel except Nitronic 60 or 660 stainless steel stem, hard-surfaced body and plug suitable from +700°F to +1,500°F (+371°C to +816°C). Hot tested. Elevated gearing.

NACE Construction Valves for Sour Gas Applications

NACE, the National Association of Corrosion Engineers, has published a report outlining acceptable materials for valves for sour service. The current outline is Publication MR0175-2002, and is a guide to the manufacturers and users of valves based on the latest metallurgical knowledge. Most of our customers involved in this area of production also have their own specifications that may or

may not be more stringent than the NACE publication. The reason for this is, of course, that the product varies from field to field and many different types of inhibitors are used.

The basic problem is that whenever even a small amount of hydrogen sulfide (H₂S) is encountered in natural gas or under oil pressure, a corrosion phenomenon may occur, known as hydrogen sulfide embrittlement or sulfide stress cracking. Actually, the steel part is absorbing hydrogen. This causes ductility, and when other stresses are added, may result in failure of the part. Currently, we know that some steels with yield strengths above 90,000 psi (621 MPa) and/or hardness greater than Rockwell 22 (235 Brinell) are subject to sulfide stress cracking. Failure below these limits is unlikely.

Because of a long history of reliability in numerous sour gas installations, Dynamic Balance valves can be supplied in conformance to standards enumerated in the NACE governing document on sour gas application.

In some cases, a more sophisticated construction may be required because of other corrosive elements in the flow stream. All major components are heat-treated to a controlled hardness of 22 or lower on the Rockwell C scale. In this construction, the plug is coated with electrolysis nickel to prevent galling.

Complete engineering details are available upon request.

Dynamic Balance Plug Valve Metals

Carbon Steel: Cast carbon steel used in Dynamic Balance valve bodies is a medium carbon steel, conforming to ASTM Specification A216, Grade WCC.

Each heat is rigidly controlled and recorded. The castings are marked to identify the heat used in each finished valve.

Steel plugs for carbon steel valves are made of a low alloy steel, heat-treated to produce the proper balance between non-galling properties and the toughness required to resist the mechanical loads imposed in operating the valve.

Manganese-Molybdenum Alloy Steel: (API Type 60K Specification – ASTM Specification A-487 Grade 4 Class C).

This alloy steel is used for body castings for 3000 MOP and higher Dynamic Balance valves for oilfield services, that must conform to API Specification 6A, covering Steel Valves for Drilling and Production Service.

Ferritic Steel: Grade LCC Ferritic Steel, conforming to ASTM Specification A352, is basically a “killed” mild carbon steel that has good impact qualities at low temperatures.

This material is used generally for sub-zero temperatures to -50°F (-46°C) and must have a minimum average Charpy “V” notch impact strength of 15 foot pounds at that temperature.

Type CF8M Stainless Steel: This is an 18-12 type of stainless steel casting material, containing molybdenum, with analysis and properties closely corresponding to AISI Type 316 wrought stainless steel, and conforming to ASTM Specification A351, Grade CF8M.

Actuators for Dynamic Balance Valves

Flowserve Nordstrom Valves can supply hydraulic, pneumatic or electric power actuators for mechanical operation of Dynamic Balance valves. To obtain equipment in close conformance with customer requirements, the following information should be provided at the time of the inquiry:

1. Valve size and pressure class:
If the power actuator is being ordered for field conversion, describe the actuator currently installed on the valve.
2. Minimum and maximum temperature valve will experience.
3. Fluid passing through valve.
4. Sealant currently being used.
5. Type of actuator desired:
 - A. Hydraulic
 - B. Pneumatic
 - C. Electric
6. Maximum differential pressure across valve during operation.
7. Speed of operation required in minutes or seconds:
 - A. To open
 - B. To close
8. Frequency of operation.
9. For an electric operator, specify:
 - A. AC or DC voltage
 - B. Single- or three-phase
 - C. Type of motor:
 1. Explosion-proof
 2. Weatherproof
 3. Other
 - D. Frequency
10. If pneumatic or hydraulic actuator is desired, specify:
 - A. Minimum and maximum pressure available.
 - B. Operating medium:
 1. Gas
 2. Air
 3. Fluid (specify type)
- C. Accessory equipment desired:
 1. Filter
 2. Pump
 3. Control valving:
 - a. Electrically operated
 - b. Manually operated
 - c. Pilot-operated
11. Position indicator (visual indicator on valves is standard):
 - A. Remote reading:
 1. Selsyn
 2. Potentiometer
12. Full instrumentation to be furnished by:
 - A. Flowserve Nordstrom Valves
 - B. Others

Wrenches and Adapters

2" Square Adapters for Dynamic Balance and Super Nordstrom Valves with Obround Wrench Heads

Distance Across Flats of Obround Wrench Head on Valve (See Dimension "J")*	Adapter Part No.
.62	61291
16	
.81	12180
21	
.88	12181
22	
1.00	12183
25	
1.25	12185
32	
1.38	12186
35	

* For dimension "J" refer to valve dimension tables.



Cast Wrench For Dynamic Balance Valves

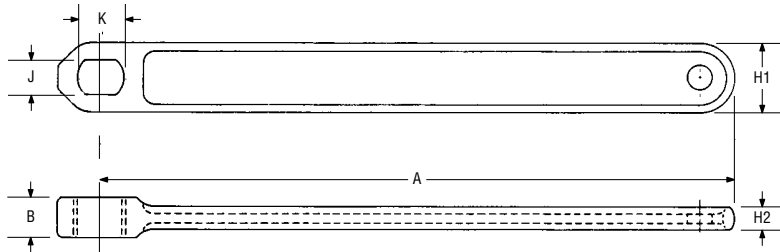

Black numerals are in inches and pounds.

Blue numerals are in millimeters and kilograms.

Size	Part #	Weight	A	B	H1	H2	J	K
DB-1	482014	2.0	18.0	.9	1.4	.4	.655	.875
		.9	457	23	35	11	17	22

Cast Heads Fitted with Pipe Handle for Dynamic Balance Valves

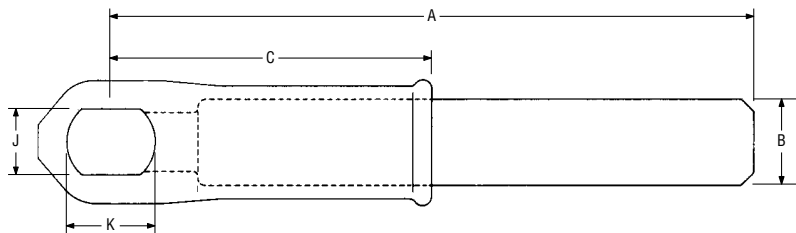

Size	Part #	Weight	A	B Dia.	C	J	K
DB-2	482006	3.7	27	1.1	4.0	.835	1.13
		2	686	27	102	21	29
DB-3	482137	6.8	36	1.3	4.7	1.03	1.44
		3	914	33	119	26	37
DB-4	482138	12.9	48	1.9	5.5	1.28	1.82
		6	1219	49	140	33	46

Locking Devices for Dynamic Balance Straightway Valves

Valve Size/Inches	1/2-3/4-1 All Classes	1 1/2-2 All Classes	2 1/2-3 All Classes (Also size 4, Class 150-600)	4 ASME Class 900-2500 API 3000 & 5000 (Also size 6 & 8, ASME Class 150-600)
Yoke	482811	482814	482817	482820
Cover	482812	482815	482818	482821
Retaining Ring	908623	908624	927389	946031
Complete Assembly	482813	482816	482819	482822

Drilling Templates, Flange and Ring Joint Dimensions, and Bolting Data for Steel Flanges

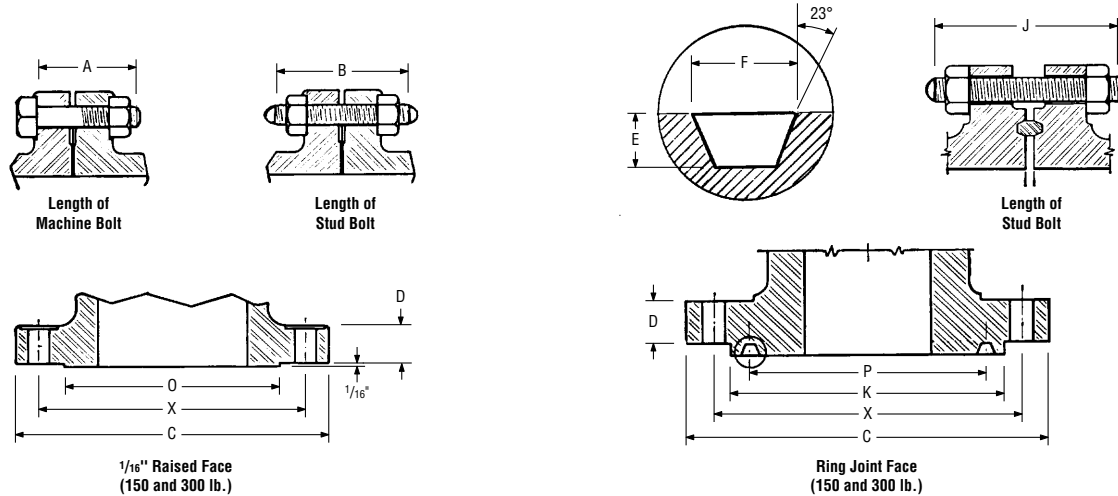

ASME Class 150 Steel Flange Standard (ASME B16.5-2003) Dimensions in Inches

Nom. Pipe Size	Flange Dimensions		Facing Dimensions						Drilling			*Length of Bolts		
			Raised Face	Ring Joint				Stud Bolts				Mach. Bolts		
	Dia. of Flange	Thickness of Flange		Dia. of 1/16" Raised Face	Ring No.	Pitch Dia. of Groove	Depth of Groove		Width of Groove	Dia. of Raised Face	No. of Bolts		Dia. of Bolts	0.06 in. Raised Face
			C			D	O	P	E	F		K		X
1/2	3.50	0.38	1.38						2.38	4	1/2	2.25	-	2.00
3/4	3.88	0.44	1.69						2.75	4	1/2	2.50	-	2.00
1	4.25	0.50	2.00	R15	1.875	.250	.344	2.50	3.12	4	1/2	2.50	3.00	2.25
1 1/4	4.62	0.56	2.50	R17	2.250	.250	.344	2.88	3.50	4	1/2	2.75	3.25	2.25
1 1/2	5.00	0.62	2.88	R19	2.562	.250	.344	3.25	3.88	4	1/2	2.75	3.25	2.50
2	6.00	0.69	3.62	R22	3.250	.250	.344	4.00	4.75	4	5/8	3.25	3.75	2.75
2 1/2	7.00	0.81	4.12	R25	4.000	.250	.344	4.75	5.50	4	5/8	3.50	4.00	3.00
3	7.50	0.88	5.00	R29	4.500	.250	.344	5.25	6.00	4	5/8	3.50	4.00	3.00
3 1/2	8.50	0.88	5.50	R33	5.188	.250	.344	6.06	7.00	8	5/8	3.50	4.00	3.00
4	9.00	0.88	6.19	R36	5.875	.250	.344	6.75	7.50	8	5/8	3.50	4.00	3.00
5	10.00	0.88	7.31	R40	6.750	.250	.344	7.62	8.50	8	3/4	3.75	4.25	3.25
6	11.00	0.94	8.50	R43	7.625	.250	.344	8.62	9.50	8	3/4	4.00	4.50	3.25
8	13.50	1.06	10.62	R48	9.750	.250	.344	10.75	11.75	8	3/4	4.25	4.75	3.50
10	16.00	1.12	12.75	R52	12.000	.250	.344	13.00	14.25	12	7/8	4.50	5.00	4.00
12	19.00	1.19	15.00	R56	15.000	.250	.344	16.00	17.00	12	7/8	4.75	5.25	4.00
14	21.00	1.31	16.25	R59	15.625	.250	.344	16.75	18.75	12	1	5.25	5.75	4.50
16	23.50	1.38	18.50	R64	17.875	.250	.344	19.00	21.25	16	1	5.25	5.75	4.50
18	25.00	1.5	21.00	R68	20.375	.250	.344	21.50	22.75	16	1 1/8	5.75	6.25	5.00
20	27.50	1.62	23.00	R72	22.000	.250	.344	23.50	25.00	20	1 1/8	6.25	6.75	5.50
24	32.00	1.81	27.25	R76	26.500	.250	.344	28.00	29.50	20	1 1/4	6.75	7.25	6.00
30**	38.75	2.12	33.75						36.00	28	1 1/4	8.12		6.38
36**	46.00	2.38	40.25						42.75	32	1 1/2	8.88		7.12

NOTE: Always check thickness of valve flanges, gaskets and companion flanges to determine correct bolt lengths required.
 * Certain valves have two or more tapped holes in end flanges requiring use of studs or cap screws.
 ** Sizes 30 and 36 valves have the same flange and drilling dimensions as Class 125 Cast Iron Flanges ASME B16.1 – 1998 except steel flange will have .06 inch raised face.

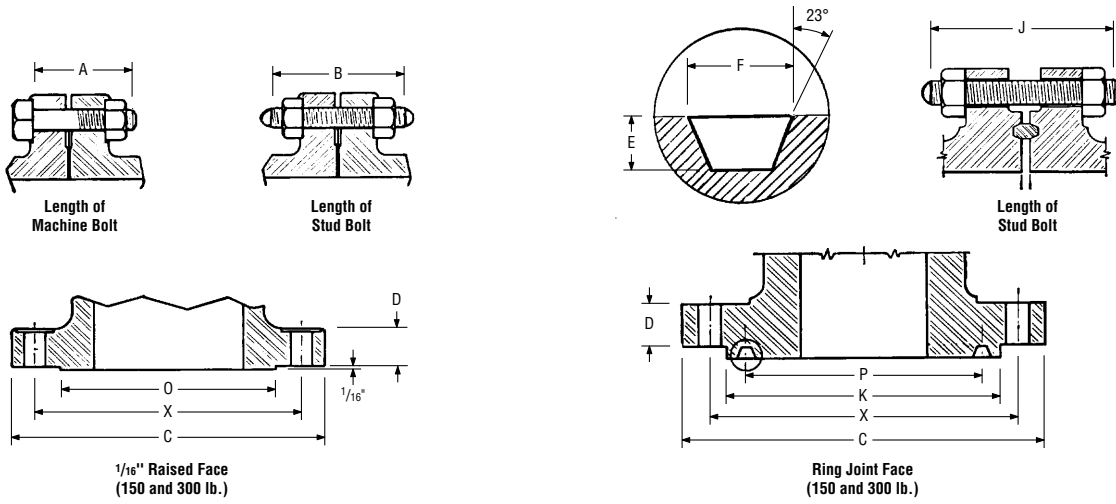

ASME Class 300 Steel Flange Standard (ASME B16.5-2003) Dimensions in Inches

Nom. Pipe Size	Flange Dimensions		Facing Dimensions						Drilling			* Length of Bolts		
			Raised Face	Ring Joint				Stud Bolts				Mach. Bolts		
	Dia. of Flange	Thickness of Flange		Dia. of 1/16" Raised Face	Ring No.	Pitch Dia. of Groove	Depth of Groove	Width of Groove	Dia. of Raised Face	Dia. of Bolt Circle	No. of Bolts		Dia. of Bolts	0.06 in. Raised Face
			C			D	O	P	E			F		K
1/2	3.75	0.50	1.38	R11	1.344	.219	.281	2.00	2.62	4	1/2	2.50	3.00	2.25
3/4	4.62	0.56	1.69	R13	1.688	.250	.344	2.50	3.25	4	5/8	3.00	3.50	2.50
1	4.88	0.62	2.00	R16	2.000	.250	.344	2.75	3.50	4	5/8	3.00	3.50	2.50
1 1/4	5.25	0.69	2.50	R18	2.375	.250	.344	3.12	3.88	4	5/8	3.25	3.75	2.75
1 1/2	6.12	0.75	2.88	R20	2.688	.250	.344	3.56	4.50	4	3/4	3.50	4.00	3.00
2	6.50	0.81	3.62	R23	3.250	.312	.469	4.25	5.00	8	5/8	3.50	4.00	3.00
2 1/2	7.50	0.94	4.12	R26	4.000	.312	.469	5.00	5.88	8	3/4	4.00	4.50	3.25
3	8.25	1.06	5.00	R31	4.875	.312	.469	5.75	6.62	8	3/4	4.25	4.75	3.50
3 1/2	9.00	1.12	5.50	R34	5.188	.312	.469	6.25	7.25	8	3/4	4.25	5.00	3.75
4	10.00	1.19	6.19	R37	5.875	.312	.469	6.88	7.88	8	3/4	4.50	5.00	3.75
5	11.00	1.31	7.31	R41	7.125	.312	.469	8.25	9.25	8	3/4	4.75	5.25	4.25
6	12.50	1.38	8.50	R45	8.312	.312	.469	9.50	10.62	12	3/4	4.75	5.50	4.25
8	15.00	1.56	10.62	R49	10.625	.312	.469	11.88	13.00	12	7/8	5.50	6.00	4.75
10	17.50	1.81	12.75	R53	12.750	.312	.469	14.00	15.25	16	1	6.25	6.75	5.50
12	20.50	1.94	15.00	R57	15.000	.312	.469	16.25	17.75	16	1 1/8	6.75	7.25	5.75
14	23.00	2.06	16.25	R61	16.500	.312	.469	18.00	20.25	20	1 1/8	7.00	7.50	6.25
16	25.50	2.19	18.50	R65	18.500	.312	.469	20.00	22.50	20	1 1/4	7.50	8.00	6.50
18	28.00	2.31	21.00	R69	21.000	.312	.469	22.62	24.75	24	1 1/4	7.75	8.25	6.75
20	30.50	2.44	23.00	R73	23.000	.375	.531	25.00	27.00	24	1 1/4	8.00	8.75	7.25
24	36.00	2.69	27.25	R77	27.250	.438	.656	29.50	32.00	24	1 1/2	9.00	10.00	8.00

NOTE: Always check thickness of valve flanges, gaskets and companion flanges to determine correct bolt lengths required.
 * Certain valves have two or more tapped holes in end flanges requiring use of studs or cap screws.

Bolt Stud Length "B" also applies for Tongue-to-Groove Flanged Joint

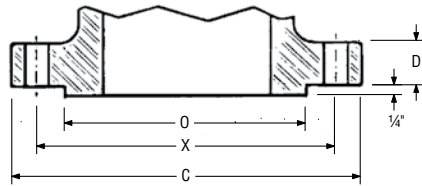
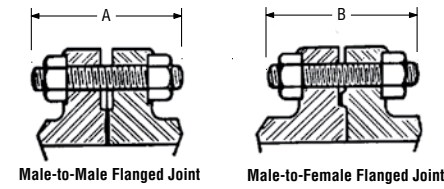

1/4" Raised Face
(400 to 2500 lb.)

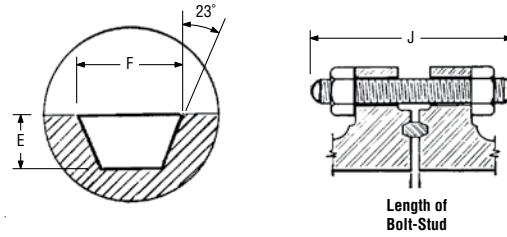

Length of Bolt-Stud

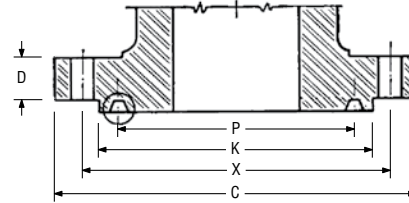

Ring Joint Face
(400 to 2500 lb.)

Nom. Pipe Size	Flange Dimensions		Facing Dimensions						Drilling			* Length of Stud-Bolts		
			Raised Face	Ring Joint				Dia. of Bolt Circle				No. of Bolts	Dia. of Bolts	Stud Bolts
	Dia. of 1/16" Raised Face	Ring No.		Pitch Dia. of Groove	Depth of Groove	Width of Groove	Dia. of Raised Face		0.25 in. Raised Face	Male & Female Tongue & Groove	Ring Joint			
			C					D				O	P	E

ASME Class 400 Steel Flange Standard (ASME B16.5-2003) Dimensions in Inches

Sizes 1/2 through 3 1/2 – Use Class 600 Dimensions														
4	10.00	1.38	6.19	R37	5.875	.312	.469	6.88	7.88	8	3/8	5.50	5.25	5.50
5	11.00	1.50	7.31	R41	7.125	.312	.469	8.25	9.25	8	3/8	5.75	5.50	5.75
6	12.50	1.62	8.50	R45	8.312	.312	.469	9.50	10.62	12	3/8	6.00	5.75	6.00
8	15.00	1.88	10.62	R49	10.625	.312	.469	11.88	13.00	12	1	6.75	6.50	6.75
10	17.50	2.12	12.75	R53	12.750	.312	.469	14.00	15.25	16	1 1/8	7.50	7.25	7.50
12	20.50	2.25	15.00	R57	15.000	.312	.469	16.25	17.75	16	1 1/4	8.00	7.75	8.00
14	23.00	2.38	16.25	R61	16.500	.312	.469	18.00	20.25	20	1 1/4	8.25	8.00	8.25
16	25.50	2.50	18.50	R65	18.500	.312	.469	20.00	22.50	20	1 3/8	8.75	8.50	8.75
18	28.00	2.62	21.00	R69	21.000	.312	.469	22.62	24.75	24	1 3/8	9.00	8.75	9.00
20	30.50	2.75	23.00	R73	23.000	.375	.531	25.00	27.00	24	1 1/2	9.50	9.25	9.75
24	36.00	3.00	27.25	R77	27.250	.438	.656	29.50	32.00	24	1 3/4	10.50	10.25	11.00

NOTE: Always check thickness of valve flanges, gaskets and companion flanges to determine correct bolt lengths required.
* Certain valves have two or more tapped holes in end flanges requiring use of studs or cap screws.

Bolt Stud Length "B" also applies for Tongue-to-Groove Flanged Joint

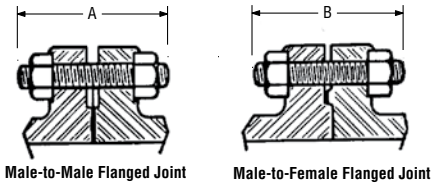

Male-to-Male Flanged Joint Male-to-Female Flanged Joint

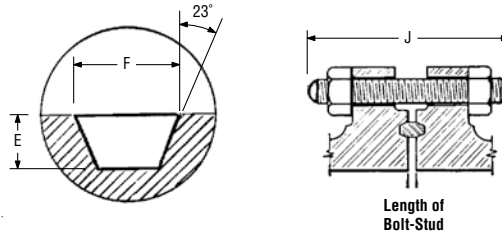

Length of Bolt-Stud

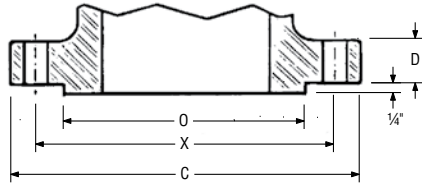

1/4" Raised Face
(400 to 2500 lb.)

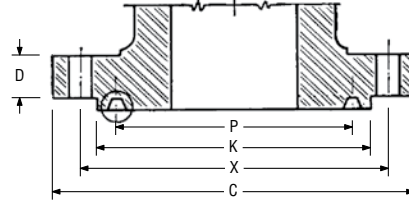

Ring Joint Face
(400 to 2500 lb.)

Nom. Pipe Size	Flange Dimensions		Facing Dimensions					Drilling			* Length of Stud-Bolts			
			Raised Face	Ring Joint							Stud Bolts		Mach. Bolts	
	Dia. of 1/4" Raised Face	Ring No.		Pitch Dia. of Groove	Depth of Groove	Width of Groove	Dia. of Raised Face	Dia. of Bolt Circle	No. of Bolts	Dia. of Bolts	0.25 in. Raised Face	Male & Female Tongue & Groove		Ring Joint
			C								D	O	P	E
1/2	3.75	.56	1.38	R11	1.344	.219	.281	2.00	2.62	4	1/2	3.00	2.75	3.00
3/4	4.62	.62	1.69	R13	1.688	.250	.344	2.50	3.25	4	5/8	3.50	3.25	3.50
1	4.88	.69	2.00	R16	2.000	.250	.344	2.75	3.50	4	5/8	3.50	3.25	3.50
1 1/4	5.25	.81	2.50	R18	2.375	.250	.344	3.12	3.88	4	5/8	3.75	3.50	3.75
1 1/2	6.12	.88	2.88	R20	2.688	.250	.344	3.56	4.50	4	3/4	4.25	4.00	4.25
2	6.50	1.00	3.62	R23	3.250	.312	.469	4.25	5.00	8	5/8	4.25	4.00	4.25
2 1/2	7.50	1.12	4.12	R26	4.000	.312	.469	5.00	5.88	8	3/4	4.75	4.50	4.75
3	8.25	1.25	5.00	R31	4.875	.312	.469	5.75	6.62	8	3/4	5.00	4.75	5.00
3 1/2	9.00	1.38	5.50	R34	5.188	.312	.469	6.25	7.25	8	7/8	5.50	5.25	5.50
4	10.75	1.50	6.19	R37	5.875	.312	.469	6.88	8.50	8	7/8	5.75	5.50	5.75
5	13.00	1.75	7.31	R41	7.125	.312	.469	8.25	10.50	8	1	6.50	6.25	6.50
6	14.00	1.88	8.50	R45	8.312	.312	.469	9.50	11.50	12	1	6.75	6.50	6.75
8	16.50	2.19	10.62	R49	10.625	.312	.469	11.88	13.75	12	1 1/8	7.50	7.25	7.75
10	20.00	2.50	12.75	R53	12.750	.312	.469	14.00	17.00	16	1 1/4	8.50	8.25	8.50
12	22.00	2.62	15.00	R57	15.000	.312	.469	16.25	19.25	20	1 1/4	8.75	8.50	8.75
14	23.75	2.75	16.25	R61	16.500	.312	.469	18.00	20.75	20	1 3/8	9.25	9.00	9.25
16	27.00	3.00	18.50	R65	18.500	.312	.469	20.00	23.75	20	1 1/2	10.00	9.75	10.00
18	29.25	3.25	21.00	R69	21.000	.312	.469	22.62	25.75	20	1 5/8	10.75	10.50	10.75
20	32.00	3.50	23.00	R73	23.000	.375	.531	25.00	28.50	24	1 5/8	11.25	11.00	11.50
24	37.00	4.00	27.25	R77	27.250	.438	.656	29.50	33.00	24	1 3/4	13.00	12.75	13.25

NOTE: Always check thickness of valve flanges, gaskets and companion flanges to determine correct bolt lengths required.
* Certain valves have two or more tapped holes in end flanges requiring use of studs or cap screws.

Nom. Pipe Size	Flange Dimensions		Facing Dimensions						Drilling			* Length of Stud-Bolt		
	Dia. of Flange	Thickness of Flange	Raised Face	Ring Joint					Dia. of Bolt Circle	No. of Bolts	Dia. of Bolts	0.25 in. Raised Face	Male & Female Tongue & Groove	Ring Joint
			Dia. of ¼" Raised Face	Ring No.	Pitch Dia. of Groove	Depth of Groove	Width of Groove	Dia. of Raised Face						
	C	D	O						P	E	F	K	X	A
ASME Class 900 Steel Flange Standard (ASME B16.5-2003) Dimensions in Inches														
Sizes ½ through 2½ – Use Class 1500 Dimensions														
3	9.50	1.50	5.00	R31	4.875	.312	.469	6.12	7.50	8	¾	5.75	5.50	5.75
4	11.50	1.75	6.19	R37	5.875	.312	.469	7.12	9.25	8	1½	6.75	6.50	6.75
5	13.75	2.00	7.31	R41	7.125	.312	.469	8.50	11.00	8	1¼	7.50	7.25	7.50
6	15.00	2.19	8.50	R45	8.312	.312	.469	9.50	12.50	12	1½	7.50	7.25	7.75
8	18.50	2.50	10.62	R49	10.625	.312	.469	12.12	15.50	12	1¾	8.75	8.50	8.75
10	21.50	2.75	12.75	R53	12.750	.312	.469	14.25	18.50	16	1¾	9.25	9.00	9.25
12	24.00	3.12	15.00	R57	15.000	.312	.469	16.50	21.00	20	1¾	10.00	9.75	10.00
14	25.25	3.38	16.25	R62	16.500	.438	.656	18.38	22.00	20	1½	10.75	10.50	11.00
16	27.75	3.50	18.50	R66	18.500	.438	.656	20.62	24.25	20	1¾	11.25	11.00	11.50
18	31.00	4.00	21.00	R70	21.000	.500	.781	23.38	27.00	20	1¾	12.75	12.50	13.25
20	33.75	4.25	23.00	R74	23.000	.500	.781	25.50	29.50	20	2	13.75	13.50	14.25
24	41.00	5.50	27.25	R78	27.250	.625	1.062	30.38	35.50	20	2½	17.25	17.00	18.00
ASME Class 1500 Steel Flange Standard (ASME B16.5-2003) Dimensions in Inches														
½	4.75	.88	1.38	R12	1.562	.250	.344	2.38	3.25	4	¾	4.25	4.00	4.25
¾	5.12	1.00	1.69	R14	1.750	.250	.344	2.62	3.50	4	¾	4.50	4.25	4.50
1	5.88	1.12	2.00	R16	2.000	.250	.344	2.81	4.00	4	¾	5.00	4.75	5.00
1¼	6.25	1.12	2.50	R18	2.375	.250	.344	3.19	4.38	4	¾	5.00	4.75	5.00
1½	7.00	1.25	2.88	R20	2.688	.250	.344	3.62	4.88	4	1	5.50	5.25	5.50
2	8.50	1.50	3.62	R24	3.750	.312	.469	4.88	6.50	8	¾	5.75	5.50	5.75
2½	9.62	1.62	4.12	R27	4.250	.312	.469	5.38	7.50	8	1	6.25	6.00	6.25
3	10.50	1.88	5.00	R35	5.375	.312	.469	6.62	8.00	8	1½	7.00	6.75	7.00
4	12.25	2.12	6.19	R39	6.375	.312	.469	7.62	9.50	8	1¼	7.75	7.50	7.75
5	14.75	2.88	7.31	R44	7.625	.312	.469	9.00	11.50	8	1½	9.75	9.50	9.75
6	15.50	3.25	8.50	R46	8.312	.375	.531	9.75	12.50	12	1¾	10.25	10.00	10.50
8	19.00	3.62	10.62	R50	10.625	.438	.656	12.50	15.50	12	1¾	11.50	11.25	12.75
10	23.00	4.25	12.75	R54	12.750	.438	.656	14.62	19.00	12	1¾	13.25	13.00	13.50
12	26.50	4.88	15.00	R58	15.000	.562	.906	17.25	22.50	16	2	14.75	14.50	15.25
14	29.50	5.25	16.25	R63	16.500	.625	1.062	19.25	25.00	16	2¼	16.00	15.75	16.75
16	32.50	5.75	18.50	R67	18.500	.688	1.188	21.50	27.75	16	2½	17.50	17.25	18.50
18	36.00	6.38	21.00	R71	21.000	.688	1.188	24.12	30.50	16	2¾	19.50	19.25	20.75
20	38.75	7.00	23.00	R75	23.000	.688	1.312	26.50	32.75	16	3	21.25	21.00	22.25
24	46.00	8.00	27.25	R79	27.250	.812	1.438	31.25	39.00	16	3½	24.25	24.00	25.50
ASME Class 2500 Steel Flange Standard (ASME B16.5-2003) Dimensions in Inches														
½	5.25	1.19	1.38	R13	1.688	.250	.344	2.56	3.50	4	¾	4.75	4.50	4.75
¾	5.50	1.25	1.69	R16	2.000	.250	.344	2.88	3.75	4	¾	5.00	4.75	5.00
1	6.25	1.38	2.00	R18	2.375	.250	.344	3.25	4.25	4	¾	5.50	5.25	5.50
1¼	7.25	1.50	2.50	R21	2.844	.312	.469	4.00	5.12	4	1	6.00	5.75	6.00
1½	8.00	1.75	2.88	R23	3.250	.312	.469	4.50	5.75	4	1½	6.75	6.50	6.75
2	9.25	2.00	3.62	R26	4.000	.312	.469	5.25	6.75	8	1	7.00	6.75	7.00
2½	10.50	2.25	4.12	R28	4.375	.375	.531	5.88	7.75	8	1½	7.75	7.50	8.00
3	12.00	2.62	5.00	R32	5.000	.375	.531	6.62	9.00	8	1¼	8.75	8.50	9.00
4	14.00	3.00	6.19	R38	6.188	.438	.656	8.00	10.75	8	1½	10.00	9.75	10.25
5	16.50	3.62	7.31	R42	7.500	.500	.781	9.50	12.75	8	1¾	11.75	11.50	12.25
6	19.00	4.25	8.50	R47	9.000	.500	.781	11.00	14.50	8	2	13.50	13.25	14.00
8	21.75	5.00	10.62	R51	11.000	.562	.906	13.38	17.25	12	2	15.00	14.75	15.50
10	26.50	6.50	12.75	R55	13.500	.688	1.188	16.75	21.25	12	2½	19.25	19.00	20.00
12	30.00	7.25	15.00	R60	16.000	.688	1.312	19.50	24.38	12	2¾	21.25	21.00	22.00

NOTE: Always check thickness of valve flanges, gaskets and companion flanges to determine correct bolt lengths required.
 * Certain valves have two or more tapped holes in end flanges requiring use of studs or cap screws.

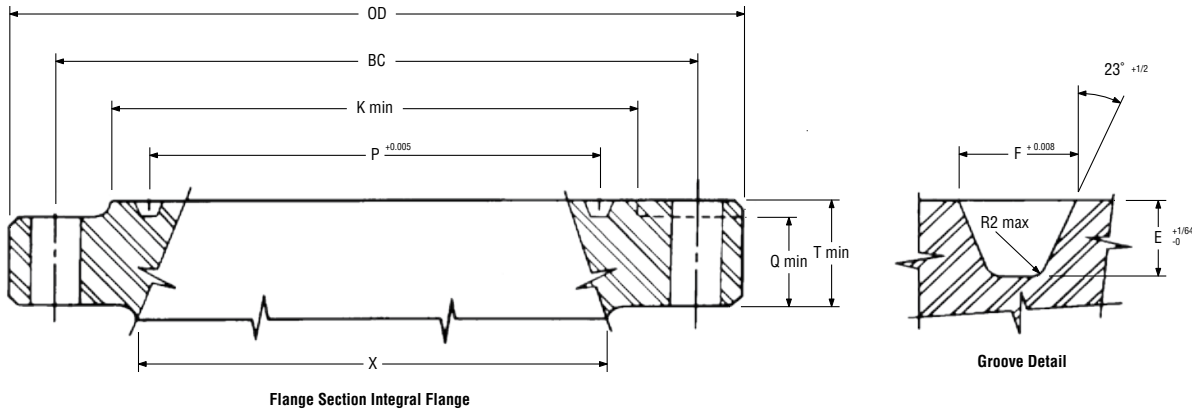

Nom. Pipe Size	Basic Flange Dimensions			Bolting Dimensions					Ring Joint Groove and Flange Facing Dimensions				
	Outside Dia. of Flange	Total Thickness of Flange	Basic Thickness of Flange	Dia. of Hub	Dia. of Bolt Circle	No. of Bolts	Dia. of Bolts	Length of Stud Bolts	Ring No.	Pitch Dia. of Type R Ring & Groove	Width of Groove	Depth of Groove	Dia. of Raised Face
	OD	T	Q	X	BC			Lssb	R or RX	P	F	E	K
API 6B Flanges for 2000 psi Rated Working Pressure Dimensions in Inches													
2½	6.50	1.31	1.00	3.31	5.00	8	¾	4.50	23	3.250	.469	.31	4.25
2¾	7.50	1.44	1.12	3.94	5.88	8	¾	5.00	26	4.000	.469	.31	5.00
3½	8.25	1.56	1.25	4.62	6.62	8	¾	5.25	31	4.875	.469	.31	5.75
4½	10.75	1.81	1.50	6.00	8.50	8	¾	6.00	37	5.875	.469	.31	6.88
5½	13.00	2.06	1.75	7.44	10.50	8	1	6.75	41	7.125	.469	.31	8.25
7½	14.00	2.19	1.88	8.75	11.50	12	1	7.00	45	8.313	.469	.31	9.50
9	16.50	2.50	2.19	10.75	13.75	12	1½	8.00	49	10.625	.469	.31	11.88
11	20.00	2.81	2.50	13.50	17.00	16	1¼	8.75	53	12.750	.469	.31	14.00
13½	22.00	2.94	2.62	15.75	19.25	20	1¼	9.00	57	15.000	.469	.31	16.25
16¾	27.00	3.31	3.00	19.50	23.75	20	1½	10.25	65	18.500	.469	.31	20.00
21¼	32.00	3.88	3.50	24.00	28.50	24	1¾	11.75	73	23.000	.531	.38	25.00
API 6B Flanges for 3000 psi Rated Working Pressure Dimensions in Inches													
2½	8.50	1.81	1.50	4.12	6.50	8	¾	6.00	24	3.750	.469	.31	4.88
2¾	9.62	1.94	1.62	4.88	7.50	8	1	6.50	27	4.250	.469	.31	5.38
3½	9.50	1.81	1.50	5.00	7.50	8	¾	6.00	31	4.875	.469	.31	6.12
4½	11.50	2.06	1.75	6.25	9.25	8	1½	7.00	37	5.875	.469	.31	7.12
5½	13.75	2.31	2.00	7.50	11.00	8	1¼	7.75	41	7.125	.469	.31	8.50
7½	15.00	2.50	2.19	9.25	12.50	12	1½	8.00	45	8.313	.469	.31	9.50
9	18.50	2.81	2.50	11.75	15.50	12	1¾	9.00	49	10.625	.469	.31	12.12
11	21.50	3.06	2.75	14.50	18.50	16	1¾	9.50	53	12.750	.469	.31	14.25
13½	24.00	3.44	3.12	16.50	21.00	20	1¾	10.25	57	15.000	.469	.31	16.50
16¾	27.75	3.94	3.50	20.00	24.25	20	1¾	11.75	66	18.500	.656	.44	20.62
20¾	33.75	4.75	4.25	24.50	29.50	20	2	14.50	74	23.000	.781	.50	25.50
API 6B Flanges for 5000 psi Rated Working Pressure Dimensions in Inches													
2½	8.50	1.81	1.50	4.12	6.50	8	¾	6.00	24	3.750	.469	.31	4.88
2¾	9.62	1.94	1.62	4.88	7.50	8	1	6.50	27	4.250	.469	.31	5.38
3½	10.50	2.19	1.88	5.25	8.00	8	1½	7.25	35	5.375	.469	.31	6.62
4½	12.25	2.44	2.12	6.38	9.50	8	1¼	8.00	39	6.375	.469	.31	7.62
5½	14.75	3.19	2.88	7.75	11.50	8	1½	10.00	44	7.625	.469	.31	9.00
7½	15.50	3.62	3.25	9.00	12.50	12	1¾	10.75	46	8.313	.531	.38	9.75
9	19.00	4.06	3.62	11.50	15.50	12	1¾	12.00	50	10.625	.656	.44	12.50
11	23.00	4.69	4.25	14.50	19.00	12	1¾	13.75	54	12.750	.656	.44	14.63

NOTE: Always check thickness of valve flanges, gaskets and companion flanges to determine correct bolt lengths required.

Typical Materials of Construction

Size 4 and Smaller Valves					
Part Name	ASME and API 6D Valves				API 6A Valves
	Category A	Category B	Category C	Category D	Category C OS ⁽⁴⁾
Adjusting Screw	Alloy Steel				
Adjusting Screw Cap	Carbon Steel				
Ball	Stainless Steel			K-500 Monel	
Body ⁽¹⁾	A216GrWCC	A352GrLCC	A216GrWCC	A352GrLCC	A487Gr4N ⁽²⁾
Bolting – Cover	A193GrB7	A320GrL7	A193GrB7M	A320GrL7M	A193GrB7M ⁽²⁾
Bolting – Gland	A193GrB7	A320GrL7	A193GrB7M	A320GrL7M	A193GrB7M ⁽²⁾
Bolting – Gear Flange	A193GrB7	A320GrL7	A193GrB7M	A320GrL7M	A193GrB7M
Check Valve	Carbon Steel		Stainless Steel		
Cover ⁽¹⁾	Carbon Steel				Carbon Steel ⁽³⁾
Diaphragm – Thick	Carbon Steel				
Diaphragm – Thin	Stainless Steel				
Equalizer	Alloy Steel		Alloy Steel .003 ENP		Alloy Steel ⁽³⁾ .003 ENP
Gasket	Graphite and Stainless Steel				
Gear Flange	Wrought Carbon Steel				Carbon Steel
Gland	Ductile Iron				Ductile Iron .003 ENP
Nameplate	Stainless Steel				
Packing	Graphite and Fluoropolymer Compound				
Plug	Steel in size 6 & 8 ASME Class 1500, and size 10 & smaller Class 2500. ASTM A-48 iron in all other sizes and ASME pressure classes. Plugs have coating of low coefficient friction material.	Alloy Steel HRC 22 Max. .003 ENP			Alloy Steel ⁽³⁾ HRC 22 Max. .003 ENP
Retaining Ring	Carbon Steel				Carbon Steel .001 ENP
Sealant Fitting	Carbon Steel				
Spring	Stainless Steel		Inconel X-750		
Stem ⁽¹⁾ (Double D)	Stainless Steel		Stainless Steel		Stainless Steel ⁽³⁾ HRC 22 Max.
Stem ⁽¹⁾ (Round w/keyway)	Wrought Carbon or Low Alloy Steel		Alloy Steel HRC 22 Max.		Alloy Steel ⁽³⁾ HRC 22 Max.
Stem Ring	Carbon Steel		Wrought Carbon Steel		
Stop Collar	Wrought Carbon Steel				Wrought Carbon Steel .001 ENP
Thrust Button	Nickel Steel		Wrought Carbon Steel		
Weatherseal – Cover	Neoprene				
Weatherseal – Stem	Buna-N				Polyurethane
Zinc Washer	Zinc				
Grease Fitting	Not Applicable				Stainless Steel

(1) Category B and D valves are impact-tested to 20/15 ft-lb values.

(2) Plastic-coated.

(3) 100% hardness-tested.

(4) OS denotes offshore construction.

Size 6 and Larger – Nonpressure Seal Valves				
ASME and API 6D Valves				
Part Name	Category A	Category B	Category C	Category D
Adjusting Screw	Carbon Steel			
Adjusting Screw Cap	Carbon Steel			
Ball – Balance	Stainless Steel		K-500 Monel	
Ball – Thrust	Stainless Steel		K-500 Monel	
Ball Retaining Washer	Stainless Steel			
Ball Seat – Thrust	Alloy Steel		Stainless Steel – Stellite Hardfaced	
Bearing (Thrust Washer)	Glass/PTFE Fiber Carbon Steel Backed		Glass/PTFE Fiber Stainless Steel Backed	
Body ⁽¹⁾	A216GrWCC	A352GrLCC	A216GrWCC	A352GrLCC
Bolting – Cover	A193GrB7	A320GrL7	A193GrB7M	A320GrL7M
Bolting – Gland	A193GrB7	A320GrL7	A193GrB7M	A320GrL7M
Bolting – Gland Retainer	A193GrB7	A320GrL7	A193GrB7M	A320GrL7M
Bolting – Gear Flange	A193GrB7	A320GrL7	A193GrB7M	A320GrL7M
Bolting – Adj. Screw Cover	SAE Gr 5			
Check Valve	Carbon Steel		Stainless Steel	
Cover ⁽¹⁾	Carbon Steel			
Diaphragm – Thick	Carbon Steel			
Diaphragm – Thin	Stainless Steel			
Equalizer	Alloy Steel		Alloy Steel .003 ENP	
Gasket – Cover	Carbon Steel			
Gasket – Adj. Screw Cover	ACCPAC N 820D			
Gear Flange	Carbon Steel			
Gland – Wrench-Operated	Ductile Iron			
Gland – Gear-Operated	Gray Iron			
Gland Retainer	Carbon Steel			
Key	Carbon Steel			
Nameplate	Stainless Steel			
Packing	Graphite and Fluoropolymer Compound			
Plug	A48Gr45B/50B or Carbon Steel		Alloy Steel HRC 22 Max. .003 ENP	
Retaining Ring	Carbon Steel			
Sealant Fitting	Carbon Steel			
Spring	Stainless Steel		Inconel X-750	
Stem ⁽¹⁾ (Double D)	Stainless Steel		Stainless Steel Double Age Hardened	
Stem ⁽¹⁾ (Round w/keyway)	Alloy Steel		Alloy Steel HRC 22 Max. .003 ENP	
Stem Ring	Carbon Steel			
Stop Collar	Wrought Carbon Steel			
Thrust Button	Wrought Carbon Steel			
Weatherseal – Cover	Neoprene			
Weatherseal – Stem	Buna-N			
Zinc Washer	Zinc			

(1) Category B and D valves are impact-tested to 20/15 ft-lb values.

Size 6 and Larger – Pressure Seal Valves				
ASME and API 6D Valves				
Part Name	Category A	Category B	Category C	Category D
Adjusting Screw	Alloy Steel			
Adjusting Screw Cap	Carbon Steel			
Ball – Balance	Stainless Steel		K-500 Monel	
Ball Retaining Washer	Stainless Steel			
Ball Seat – Thrust	Alloy Steel		Stainless Steel – Stellite Hardfaced	
Bearing (Thrust Washer, Stem)	Glass/PTFE Fiber Carbon Steel Backed		Glass/PTFE Fiber Stainless Steel Backed	
Body ⁽¹⁾	A216GrWCC	A352GrLCC	A216GrWCC	A352GrLCC
Bolting – Gland Retainer	A193GrB7	A320GrL7	A193GrB7M	A320GrL7M
Bolting – Gear Flange	A193GrB7	A320GrL7	A193GrB7M	A320GrL7M
Bolting – Packing Gland, Adjusting Screw	A193GrB7	A320GrL7	A193GrB7M	A320GrL7M
Bolting – Adj. Screw Cover	SAE Gr 5			
Check Valve	Carbon Steel		Stainless Steel	
Cover ⁽¹⁾	Carbon Steel			
Cover Retainer	Carbon Steel			
Equalizer	Alloy Steel		Alloy Steel .003 ENP	
Gasket – Pressure Seal	Carbon Steel			
Gasket – Cover	Carbon Steel			
Gland – Stem Packing	Ductile Iron			
Gland – Adjusting Screw	Gray Iron			
Gland Retainer	Carbon Steel			
Key	Carbon Steel			
Nameplate	Stainless Steel			
Packing – Stem	Graphite and Fluoropolymer Compound			
Packing – Adjusting Screw	(1) Braided Carbon Filament Yarn and (1) Graphite			
Pin – Spring Disk	Carbon Steel			
Plug	A48Gr45B/50B or Carbon Steel		Alloy Steel HRC 22 Max. .003 ENP	
Sealant Fitting	Carbon Steel			
Ring – Spacer	Carbon Steel			
Ring – Split	Alloy Steel			
Spring – Plug	Stainless Steel		Inconel X-750	
Spring Disk	Alloy Steel			
Stem ⁽¹⁾ (Gear-Operated)	Alloy Steel		Alloy Steel HRC 22 Max. .003 ENP	
Stem Ring	Carbon Steel			
Zinc Washer	Zinc			

(1) Category B and D valves are impact-tested to 20/15 ft-lb values.



Flowserve Corporation
Flowserve Flow Control
Nordstrom Valves
1511 Jefferson Street
Sulphur Springs, Texas 75482
USA
Telephone: 903-885-4691
Fax: 903-439-3411

FCD NVENBR1016-00 Printed in USA. (Replaces STL-201)

To find your local Flowserve representative:

For more information about Flowserve Corporation, visit
www.flowserve.com or call USA 1 800 225 6989

Flowserve Corporation has established industry leadership in the design and manufacture of its products. When properly selected, this Flowserve product is designed to perform its intended function safely during its useful life. However, the purchaser or user of Flowserve products should be aware that Flowserve products might be used in numerous applications under a wide variety of industrial service conditions. Although Flowserve can (and often does) provide general guidelines, it cannot provide specific data and warnings for all possible applications. The purchaser/user must therefore assume the ultimate responsibility for the proper sizing and selection, installation, operation, and maintenance of Flowserve products. The purchaser/user should read and understand the Installation Operation Maintenance (IOM) instructions included with the product, and train its employees and contractors in the safe use of Flowserve products in connection with the specific application.

While the information and specifications contained in this literature are believed to be accurate, they are supplied for informative purposes only and should not be considered certified or as a guarantee of satisfactory results by reliance thereon. Nothing contained herein is to be construed as a warranty or guarantee, express or implied, regarding any matter with respect to this product. Because Flowserve is continually improving and upgrading its product design, the specifications, dimensions and information contained herein are subject to change without notice. Should any question arise concerning these provisions, the purchaser/user should contact Flowserve Corporation at any one of its worldwide operations or offices.

© 2006 Flowserve Corporation, Irving, Texas, USA. Flowserve is a registered trademark of Flowserve Corporation.