

DM Series Diaphragm Valves

Product Data Sheet



introduction

< STANDARDS >



ASTM D1784
ASTM D1785
ASTM D2466
ASTM D2467
ASTM D2464
ASTM F1498



ANSI B1.20.1
ANSI B16.5

IPEX DM Series Diaphragm Valves are ultra-compact, direct acting pneumatic valves. The direct operation of the diaphragm does not require a closing spring, which makes the small DM particularly suitable when space is at a premium. A rugged construction allows for use with even extremely aggressive media. DM Series Diaphragm Valves are part of our complete systems of pipe, valves, and fittings, engineered and manufactured to our strict quality, performance, and dimensional standards.

Valve Availability

Body Material:	PVC
Size Range:	1/2" through 2"
Pressure:	120 psi
Diaphragm:	EPDM, Viton® (FPM)
Control Style:	Pneumatically Actuated
End Connections:	Spigot, True Union, Flanged (ANSI 150)

DM Series Diaphragm Valves

Sample Specification



1.0 Diaphragm Valves - DM

1.1 Material

- The valve body, including end connectors and unions shall be made of PVC compound which shall meet or exceed the requirements of cell classification 12454 according to ASTM D1784.
- These compounds shall comply with standards that are equivalent to NSF Standard 61 for potable water.
- The valve bonnet assembly shall be made of glass reinforced polypropylene (GRPP).

1.2 Diaphragm and O-rings

- The diaphragm shall be made of EPDM which shall comply with standards that are equivalent to NSF Standard 61 for potable water.
- or
- The diaphragm shall be made of Viton® (FPM) which shall comply with standards that are equivalent to NSF Standard 61 for potable water.

- #### 1.3
- All other wetted and non-wetted parts of the valves shall comply with standards that are equivalent to NSF Standard 61 for potable water.

2.0 Connections

2.1 Spigot style

- The IPS spigot PVC end connectors shall conform to the dimensional standard ASTM D1785.

2.2 Socket style

- The IPS socket PVC end connectors shall conform to the dimensional standards ASTM D2466 and ASTM D2467.

2.3 Threaded style

- The IPS threaded PVC end connectors shall conform to the dimensional standards ASTM D2464, ASTM F1498, and ANSI B1.20.1.

2.4 Flanged style

- The ANSI 150 flanged PVC end connectors shall conform to the dimensional standard ANSI B16.5.

3.0 Design Features

- All valves shall be weir-style for throttling applications.
- All bodies to be used with EPDM or Viton® diaphragms shall feature raised molded sealing rings (concentric).
- All through bolts shall be made of 304 stainless steel.
- Bolts will thread directly into integrally molded brass inserts in the bonnet.
- Bodies of all sizes and materials shall have mounting brass inserts.



DM Series Diaphragm Valves

Sample Specification (cont'd)



3.1 Actuators

- All actuators shall be made of glass-filled polypropylene.
- All actuators shall feature a smooth top (no nut holes) for cleanliness.
- The edge of the actuator membrane shall be inside of the actuator protective housing.

3.2 Pressure Rating

- All valves shall be rated at 120 psi at 73°F.

3.3 Markings

- All valves shall be marked to indicate size, material designation, and manufacturers name or trade mark.

3.4 Color Coding

- All PVC valves shall be color-coded dark gray.

4.0 All valves shall be Xirtec® 140 by IPEX or approved equal.

DM Series Diaphragm Valves

Valve Selection

Size (inches)	Body Material	Diaphragm Material	IPEX Part Number			Pressure Rating at 73°F
			Spigot	True Union	Flanged	
1/2	PVC	EPDM	054880	054892	054904	120 psi
		Viton®	054886	054898	054910	
3/4		EPDM	054881	054893	054905	
		Viton®	054887	054899	054911	
1		EPDM	054882	054894	054906	
		Viton®	054888	054900	054912	
1-1/4		EPDM	054883	054895	054907	
		Viton®	054889	054901	054913	
1-1/2		EPDM	054884	054896	054908	
		Viton®	054890	054902	054914	
2	EPDM	054885	054897	054909		
	Viton®	054891	054903	054915		

with stroke limiter and position indicator

Size (inches)	Body Material	Diaphragm Material	IPEX Part Number			Pressure Rating at 73°F
			Spigot	True Union	Flanged	
1/2	PVC	EPDM	054916	054928	054940	120 psi
		Viton®	054922	054934	054946	
3/4		EPDM	054917	054929	054941	
		Viton®	054923	054935	054947	
1		EPDM	054918	054930	054942	
		Viton®	054924	054936	054948	
1-1/4		EPDM	054919	054931	054943	
		Viton®	054925	054937	054949	
1-1/2		EPDM	054920	054932	054944	
		Viton®	054926	054938	054950	
2	EPDM	054921	054933	054945		
	Viton®	054927	054939	054951		

Note: True Union EPDM diaphragm valves have EPDM o-rings; True Union Viton® diaphragm valves have Viton® o-rings.

Size:

- 1/2" 1-1/4"
- 3/4" 1-1/2"
- 1" 2"

Diaphragm:

- EPDM
- Viton® (FPM)

End Connections:

- Spigot
- True Union
- Flanged

Style:

- Normal
- w/ Stroke Limiter and Position Indicator

IPEX Part Number:

DM Series Diaphragm Valves

Technical Data

dimensions

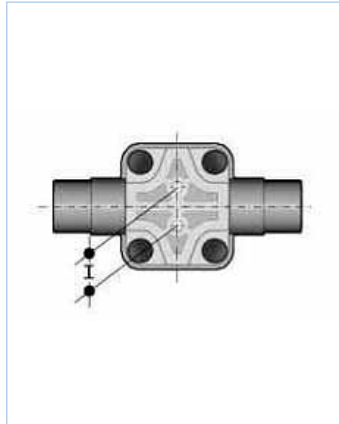
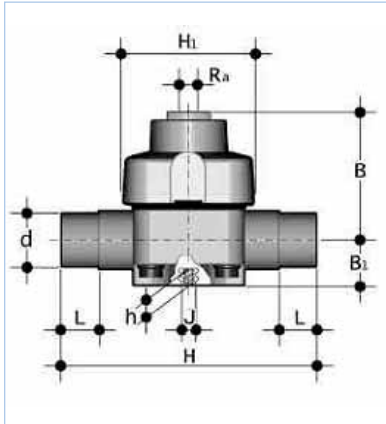

spigot connections

Size	Dimension (inches)				
	d	H	L	B ₁	B
1/2	0.84	4.88	0.63	1.02	2.60
3/4	1.05	5.67	0.75	1.02	2.60
1	1.32	6.06	0.87	1.02	2.60
1-1/4	1.66	6.85	1.02	1.57	3.70
1-1/2	1.90	7.64	1.22	1.57	3.70
2	2.38	8.82	1.50	1.57	4.45

Size	Dimension (inches)				
	H ₁	J	h	l	R _a
1/2	2.99	M6	0.47	0.98	1/4
3/4	2.99	M6	0.47	0.98	1/4
1	2.99	M6	0.47	0.98	1/4
1-1/4	3.94	M8	0.71	1.75	1/4
1-1/2	3.94	M8	0.71	1.75	1/4
2	4.53	M8	0.71	1.75	1/4

true union connections

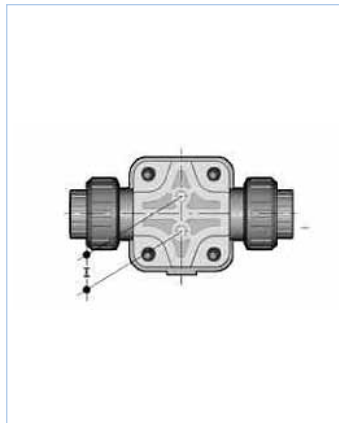
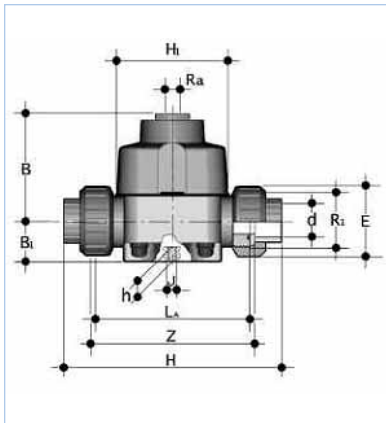

Size	Dimension (inches)					
	d	H	Z	L _A	R ₁	E
1/2	0.84	5.79	4.53	4.25	1	1.61
3/4	1.05	6.06	4.57	4.25	1-1/4	1.97
1	1.32	6.61	4.88	4.57	1-1/2	2.28
1-1/4	1.66	7.56	5.51	5.28	2	2.83
1-1/2	1.90	8.74	6.30	6.06	2-1/4	3.11
2	2.38	10.47	7.48	7.24	2-3/4	3.86

Size	Dimension (inches)						
	B ₁	B	H ₁	J	h	l	R _a
1/2	1.02	2.60	2.99	M6	0.47	0.98	1/4
3/4	1.02	2.60	2.99	M6	0.47	0.98	1/4
1	1.02	2.60	2.99	M6	0.47	0.98	1/4
1-1/4	1.57	3.70	3.94	M8	0.63	1.75	1/4
1-1/2	1.57	3.70	3.94	M8	0.63	1.75	1/4
2	1.57	4.45	4.53	M8	0.63	1.75	1/4

flanged connections

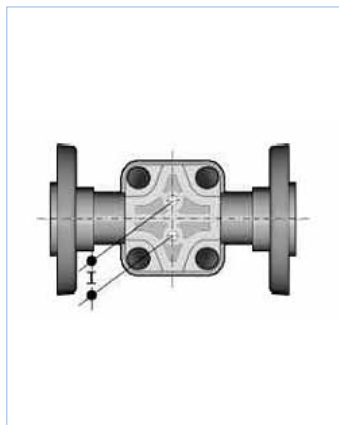
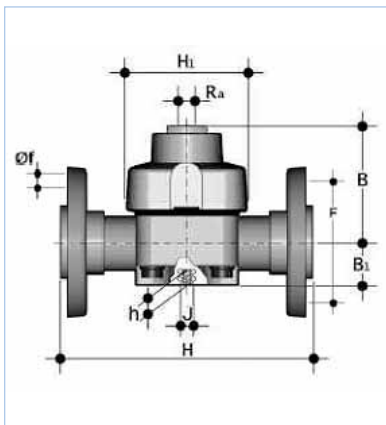

Size	Dimension (inches)				
	H	B ₁	B	H ₁	R _a
1/2	5.37	1.02	2.60	2.99	1/4
3/4	6.11	1.02	2.60	2.99	1/4
1	6.58	1.02	2.60	2.99	1/4
1-1/4	7.30	1.57	3.70	3.94	1/4
1-1/2	8.02	1.57	3.70	3.94	1/4
2	8.88	1.57	4.45	4.53	1/4

Size	Dimension (inches)					
	# holes	f	F	J	h	l
1/2	4	5/8	2-3/8	M6	0.47	0.98
3/4	4	5/8	2-3/4	M6	0.47	0.98
1	4	5/8	3-1/8	M6	0.47	0.98
1-1/4	4	5/8	3-1/2	M8	0.71	1.75
1-1/2	4	5/8	3-7/8	M8	0.71	1.75
2	4	3/4	4-3/4	M8	0.71	1.75



DM Series Diaphragm Valves

Technical Data (cont'd)

dimensions - w/ stroke limiter & position indicator spigot connections

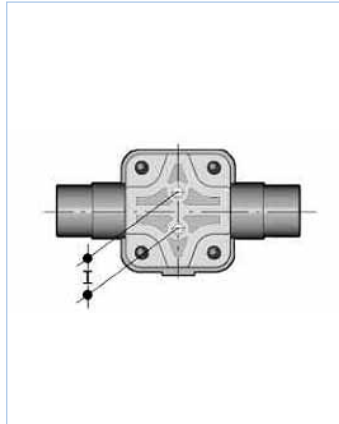
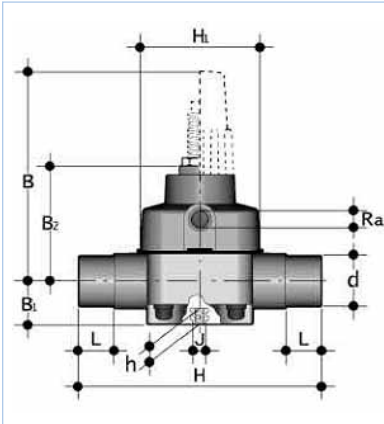

Size	Dimension (inches)					
	d	H	L	B ₁	B	B ₂
1/2	0.84	4.88	0.63	1.02	5.08	2.60
3/4	1.05	5.67	0.75	1.02	5.08	2.60
1	1.32	6.06	0.87	1.02	5.08	2.60
1-1/4	1.66	6.85	1.02	1.57	7.01	3.70
1-1/2	1.90	7.64	1.22	1.57	7.01	3.70
2	2.38	8.82	1.50	1.57	8.82	4.45

Size	Dimension (inches)				
	H ₁	J	h	l	R _a
1/2	2.99	M6	0.47	0.98	1/4
3/4	2.99	M6	0.47	0.98	1/4
1	2.99	M6	0.47	0.98	1/4
1-1/4	3.94	M8	0.71	1.75	1/4
1-1/2	3.94	M8	0.71	1.75	1/4
2	4.53	M8	0.71	1.75	1/4

true union connections

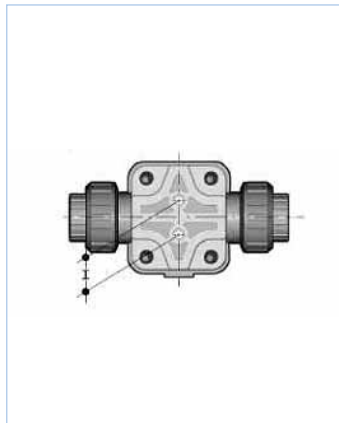
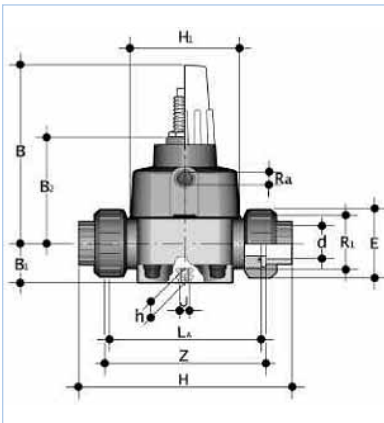

Size	Dimension (inches)						
	d	H	Z	L _A	R ₁	E	B ₁
1/2	0.84	5.79	4.53	4.25	1	1.61	1.02
3/4	1.05	6.06	4.57	4.25	1-1/4	1.97	1.02
1	1.32	6.61	4.88	4.57	1-1/2	2.28	1.02
1-1/4	1.66	7.56	5.51	5.28	2	2.83	1.57
1-1/2	1.90	8.74	6.30	6.06	2-1/4	3.11	1.57
2	2.38	10.47	7.48	7.24	2-3/4	3.86	1.57

Size	Dimension (inches)						
	B	B ₂	H ₁	J	h	l	R _a
1/2	5.08	2.60	2.99	M6	0.47	0.98	1/4
3/4	5.08	2.60	2.99	M6	0.47	0.98	1/4
1	5.08	2.60	2.99	M6	0.47	0.98	1/4
1-1/4	7.01	3.70	3.94	M8	0.63	1.75	1/4
1-1/2	7.01	3.70	3.94	M8	0.63	1.75	1/4
2	8.82	4.45	4.53	M8	0.63	1.75	1/4

flanged connections

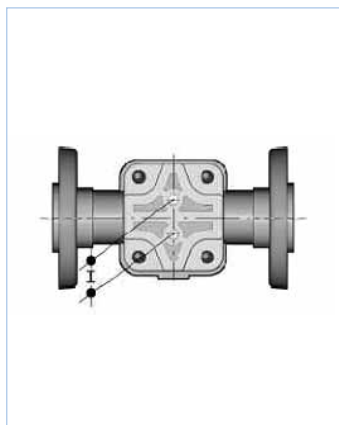
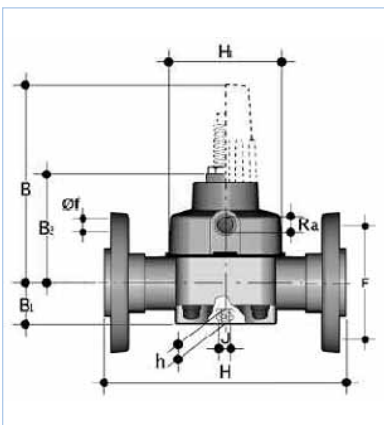

Size	Dimension (inches)					
	H	B ₁	B	B ₂	H ₁	R _a
1/2	5.37	1.02	5.08	2.60	2.99	1/4
3/4	6.11	1.02	5.08	2.60	2.99	1/4
1	6.58	1.02	5.08	2.60	2.99	1/4
1-1/4	7.30	1.57	7.01	3.70	3.94	1/4
1-1/2	8.02	1.57	7.01	3.70	3.94	1/4
2	8.88	1.57	8.82	4.45	4.53	1/4

Size	# holes	Dimension (inches)				
		f	F	J	h	l
1/2	4	5/8	2-3/8	M6	0.47	0.98
3/4	4	5/8	2-3/4	M6	0.47	0.98
1	4	5/8	3-1/8	M6	0.47	0.98
1-1/4	4	5/8	3-1/2	M8	0.71	1.75
1-1/2	4	5/8	3-7/8	M8	0.71	1.75
2	4	3/4	4-3/4	M8	0.71	1.75



DM Series Diaphragm Valves

Technical Data (cont'd)

weights



Size (inches)	Approximate Weight (lbs)					
	Normal			w/ Stroke Limiter & Position Indicator		
	Spigot	True Union	Flanged	Spigot	True Union	Flanged
1/2	0.99	1.10	1.37	1.20	1.32	1.58
3/4	0.99	1.10	1.51	1.20	1.32	1.72
1	0.99	1.10	1.71	1.20	1.32	1.92
1-1/4	2.20	2.43	3.12	2.78	2.98	3.70
1-1/2	2.20	2.43	3.42	2.78	2.98	4.00
2	3.53	3.75	5.55	4.25	4.52	6.27

pressure – temperature ratings

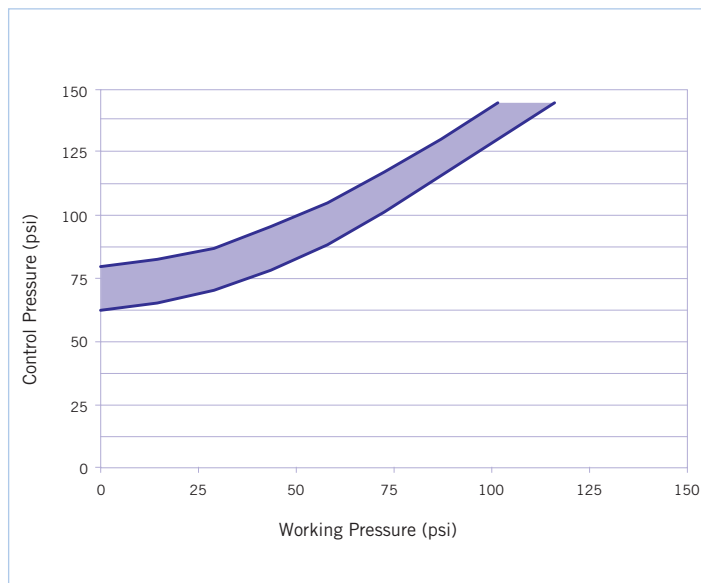
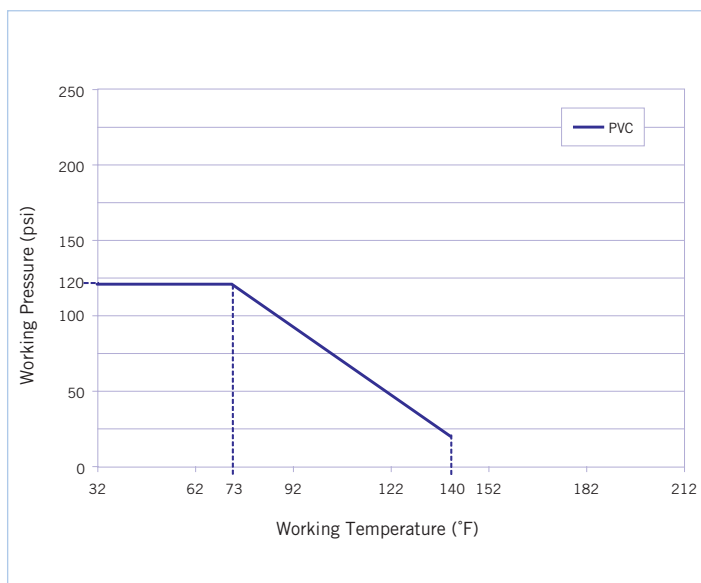

Notes:

- The maximum working pressure is 120 psi for all sizes.
- The maximum control pressure allowed for all sizes is 145 psi.
- The control fluid temperature should not exceed 125°F.

DM Series Diaphragm Valves

Technical Data (cont'd)

flow coefficients



The flow coefficient (C_v) represents the flow rate in gallons per minute (GPM) at 68°F for which there is a 1 psi pressure drop across the valve in the fully open position. These values are determined from an industry standard testing procedure which uses water as the flowing media (specific gravity of 1.0). To determine specific flow rate and pressure loss scenarios, one can use the following formula:

$$f = sg \times \left(\frac{Q}{C_v} \right)^2$$

Where,

f is the pressure drop (friction loss) in psi,

sg is the specific gravity of the fluid,

Q is the flow rate in GPM,

C_v is the flow coefficient.

Size (in)	C_v
1/2	6.51
3/4	9.52
1	12.3
1-1/4	21.0
1-1/2	29.1
2	53.6

pressure loss chart

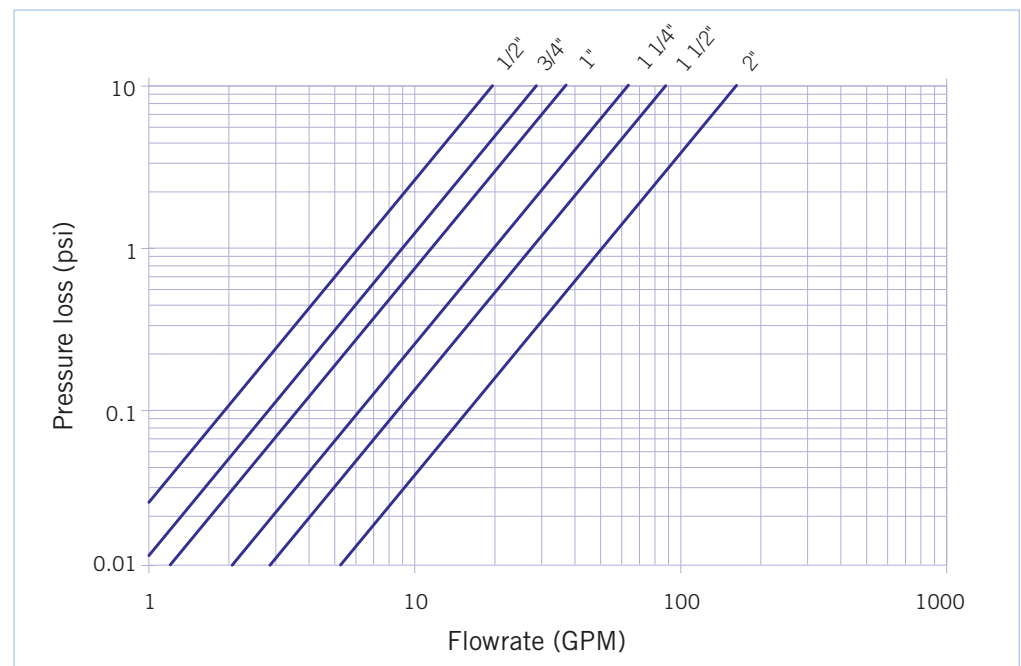

DM Series Diaphragm Valves

Components

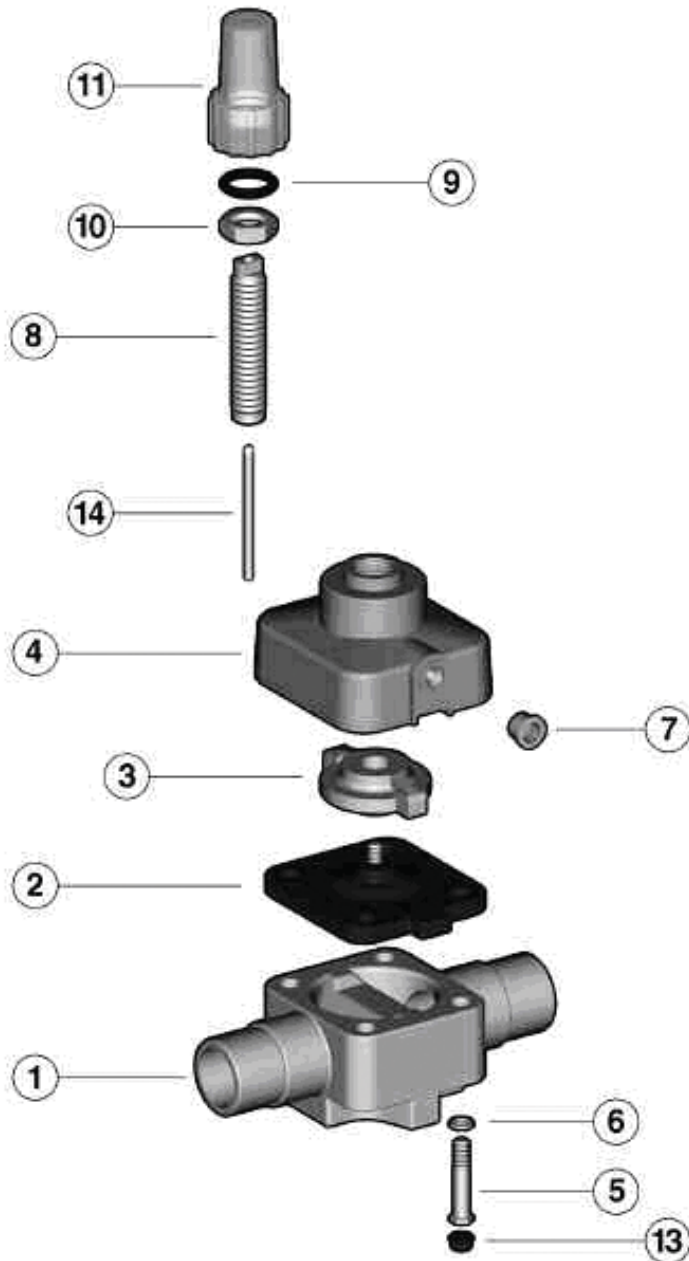

#	Component	Material	Qty
1*	valve body	PVC	1
2	diaphragm	EPDM / Viton®	1
3	compressor ¹	PBT	1
4	bonnet	GRPP	1
5	bolt	zinc plated steel	4
6	washer	zinc plated steel	4
7	plug ¹	PE	1
8	stroke limiter ¹	AL	1
9	o-ring ¹	NBR	1
10	nut ¹	zinc plated steel	1
11	protective cap ¹	PVC	1
12	plug	PE	1
13	protective cap	PE	4
14	indicator – stem ¹	polyamide	1

¹ For version w/ stroke limiter and position indicator only.

DM Series Diaphragm Valves

Installation Procedures



1. The valve may be installed in any position or direction.
2. Please refer to the appropriate connection style sub-section:
 - a. For spigot style, solvent cement each pipe onto the ends of the valve body. **Ensure that excess solvent does not run into the body of the valve.**
 - b. For true union style, remove the union nuts and slide them onto the pipe.
 - i. For socket style, solvent cement the end connectors onto the pipe ends. For correct joining procedure, please refer to the section entitled, "*Joining Methods - Solvent Cementing*" in the IPEX Industrial Technical Manual Series, "*Volume I: Vinyl Process Piping Systems*". **Ensure that excess solvent does not run into the body of the valve. Be sure to allow sufficient cure time before continuing with the valve installation.**
 - ii. For threaded style, thread the end connectors onto the pipe ends. For correct joining procedure, please refer to the section entitled, "*Joining Methods - Threading*" in the IPEX Industrial Technical Manual Series, "*Volume I: Vinyl Process Piping Systems*".
 - iii. Ensure that the socket o-rings are properly fitted in their grooves then carefully place the valve in the system between the two end connections.
 - iv. Tighten both union nuts. Hand tightening is typically sufficient to maintain a seal for the maximum working pressure. **Over-tightening may damage the threads on the valve body and/or the union nut, and may even cause the union nut to crack.**
 - c. For flanged style, join both flanges to the pipe flanges. For correct joining procedure, please refer to the section entitled, "*Joining Methods - Flanging*" in the IPEX Industrial Technical Manual Series, "*Volume I: Vinyl Process Piping Systems*".
3. Connect a suitable air supply and pilot system to the actuator. **Be sure to check that both the working and control pressure are in accordance with the specifications.**
4. If anchoring is required, fix the valve to the supporting structure using the mounting holes on the bottom of the valve body.

DM Series Diaphragm Valves

Valve Maintenance



disassembly

1. If removing the valve from an operating system, isolate the valve from the rest of the line. **Be sure to depressurize and drain the valve and isolated branch. Depressurize and disconnect the pneumatic control line before continuing with disassembly.**
2. If necessary, detach the valve from the support structure by disassembling the threaded connections on the bottom of the valve body.
3. Please refer to the appropriate connection style sub-section:
 - a. For spigot style, cut the pipe on either side of the valve and remove from the line.
 - b. For true union connections, loosen both union nuts and drop the valve out of the line. If retaining the socket o-rings, take care that they are not lost when removing the valve from the line.
 - c. For flanged style, loosen each bolt holding the valve to the pipe flanges. Please refer to the section entitled, "*Joining Methods - Flanging*" in the IPEX Industrial Technical Manual Series, "*Volume 1: Vinyl Process Piping Systems*" for a recommended bolt tightening pattern diagram. Follow the same pattern when disassembling the flanged joints then carefully remove the valve from the line.
4. Remove the protective caps then loosen and remove the bolts and washers from the bottom of the valve body.
5. Remove the diaphragm from the valve body.
6. If applicable, loosen and remove the stroke limiter and position indicator
7. The valve components can now be checked for problems and/or replaced.

assembly

Note: Before assembling the valve components, it is advisable to lubricate the o-rings with a water soluble lubricant. **Be sure to consult the "IPEX Chemical Resistance Guide" and/or other trusted resources to determine specific lubricant-rubber compatibilities.**

1. Position the diaphragm on the bonnet.
2. Place the bonnet and diaphragm onto the valve body taking care to properly line up the sealing surfaces.
3. Insert the bolts and washers and tighten in an even (cross-like) pattern.
4. Replace the protective caps.
5. If applicable, replace the stroke limiter, position indicator, and o-ring.

DM Series Diaphragm Valves

Testing and Operating



The purpose of system testing is to assess the quality of all joints and fittings to ensure that they will withstand the design working pressure, plus a safety margin, without loss of pressure or fluid. Typically, the system will be tested and assessed in sub-sections as this allows for improved isolation and remediation of potential problems. With this in mind, the testing of a specific installed valve is achieved while carrying out a test of the overall system.

An onsite pressure test procedure is outlined in the IPEX Industrial Technical Manual Series, *“Volume I: Vinyl Process Piping Systems”* under the section entitled, *“Testing”*. The use of this procedure should be sufficient to assess the quality of a valve installation. **In any test or operating condition, it is important to never exceed the pressure rating of the lowest rated appurtenance in the system.**

Important points:

- Never test thermoplastic piping systems with compressed air or other gases including air-over-water boosters.
- When testing, do not exceed the rated maximum operating pressure of the valve.
- Avoid the rapid closure of valves to eliminate the possibility of water hammer which may cause damage to the pipeline or the valve.

Please contact IPEX customer service and technical support with regard to any concern not addressed in this data sheet or the technical manual.

DM Series Diaphragm Valves

About IPEX

IPEX is a leading supplier of thermoplastic piping systems. We provide our customers with one of the world's largest and most comprehensive product lines. All IPEX products are backed by over 50 years of experience. With state-of-the-art manufacturing facilities and distribution centers across North America, the IPEX name is synonymous with quality and performance.

Our products and systems have been designed for a broad range of customers and markets. Contact us for information on:

- PVC, CPVC, PP, FR-PVDF, ABS, PEX and PE pipe and fittings ($\frac{1}{4}$ " to 48")
- Industrial process piping systems
- Double containment systems
- Acid waste systems
- High purity systems
- Industrial, plumbing and electrical cements
- Municipal pressure and gravity piping systems
- Plumbing and mechanical pipe systems
- Electrical systems
- Telecommunications systems
- Irrigation systems
- PE Electrofusion systems for gas and water
- Radiant heating systems

WARRANTY: All IPEX products are guaranteed against defects resulting from faulty workmanship or materials. If any such product is found to be defective by reason of faulty workmanship or materials, upon written notice and return of the product, the defective product will be replaced by IPEX free of charge, including shipping charges for the replacement product. Claims for labour costs and other expenses required to replace such defective product or to repair any damage resulting from the use thereof will not be allowed by IPEX. Our liability is limited to the price paid for the defective product. IPEX will not be bound by any warranty, other than the above set forth, unless such warranty is in writing.

This literature is published in good faith and is believed to be reliable. However, IPEX does not represent and/or warrant in any manner the information and suggestions contained in this brochure. Data presented is the result of laboratory tests and field experience.

IPEX maintains a policy of ongoing product improvement. This may result in modification of features and/or specifications without notice.

