

**Sure Flow
Equipment Inc.**



CHECK VALVES

*Double Door, Dual Disc, Wafer, Flanged,
Lug, Elastic Swing, Horizontal Swing, Wafer
Swing, Silent or Piston, Foot Valves*

"THE WORLD OF CHECK VALVES"

Index

Product information	2-4
Standard Materials of Construction	5
Identification Code	5
Installation Dimensions for ANSI Valves	6
Installation Dimensions for Lug Body and Flanged Body ANSI Check Valves	7
ANSI Stud Bolting Dimensions	8
Installation Data	8
Pressure Loss Through Valves	9
Seat Options	10
Quality policy	11
Cast Steel & Cast 316SS, Type CD 150 - Wafer Double Door - Dual Disc	12
Cast Iron Wafer Double Door	13
Elastic Swing Check Valve	14
Cast Iron Horizontal Swing Check Valve	15
Wafer Swing Check Valve	16
Silent Check Valve - Cast Iron Wafer	17
Carbon & Stainless Steel Wafer Silent Check Valve ...	18
Cast Iron Flanged Silent Check Valve	19
Cast Steel Flanged Silent Check Valve	20
Pressure Drop Charts	21
Foot Valve	22
Foot Valve Assembly	23
Warranty	24

Sure Flow Equipment Inc. is a worldwide leader for industrial valves and strainers, manufacturing and distributing to over 40 countries.

Sure Flow's initial focus was to supply the marketplace with an extensive line of Y-Type Strainers, Simplex Strainers, Duplex and Fabricated Strainers. The product line provides a solution to every filtration problem in every industry and if we haven't already solved your problem, our Engineers will develop the best answer.

In addition to Pipeline Strainers, Sure Flow offers Wafer Double Door Check Valves, Silent Check Valves, Butterfly Valves 2" to 48", Knife Gate Valves and Expansion Joints.

Sure Flow products are available in Cast Iron, Steel, Stainless, Bronze, and any exotic Alloy, in sizes from 1/4" to 60", 125 lb. to 2500 lb. Class, in NPT, Flanged, Butt Weld and Socket Weld.

Many design codes are available.

The Universe of Industrial Valves from



Fabricated Duplex Strainers



Cast Iron Duplex Silent Check Valve



Automatic Strainers



Y-Strainers/
Custom Screens



Strainers



Fabricated Sanitary Dual Basket Strainers



Pump Connectors



Butterfly Valves



Ball Valves



Wafer Check Valves



Knife Gate Valves

The **Sure Flow Check** wafer check valve is a precision engineered, fully developed product at the forefront of pipe system technology. **Sure Flow Check** can be installed with confidence into offshore or onshore pipeline systems on product or service lines, wherever non-return protection is required.

Manufactured to meet API specifications, **Sure Flow Check** meets all the key criteria and in the vitally important area of comparative weights is actually lighter than other wafer check valves.

Sure Flow Check offers other operational benefits. **It is light, tight, strong, compact and cost effective.**

Sure Flow Check is a precision engineered dual plate wafer check valve. It has been designed specifically for its environment and its duty. Every component has been carefully chosen only after matching its performance requirements with value analysis criteria.

The **Sure Flow Check** Valve meets API 594 wafer check valve standard (except face to face dimensions of ANSI 125 cast iron valves from 2-1/2" to 12" in which case they meet the Industry Standard).

- ANSI B16.5 flange dimension
- ANSI B16.47 above 24", flange dimension
- API 594 – materials, design & face to face
- API 605 (B16.47), flange dimension
- API 6A – flange dimension & face to face
- API 6D – materials
- API 598 – testing
- ANSI B16.34 – materials, wall thickness

Double Door or Dual Disc Available Wafer • Flanged • Hub • Lug

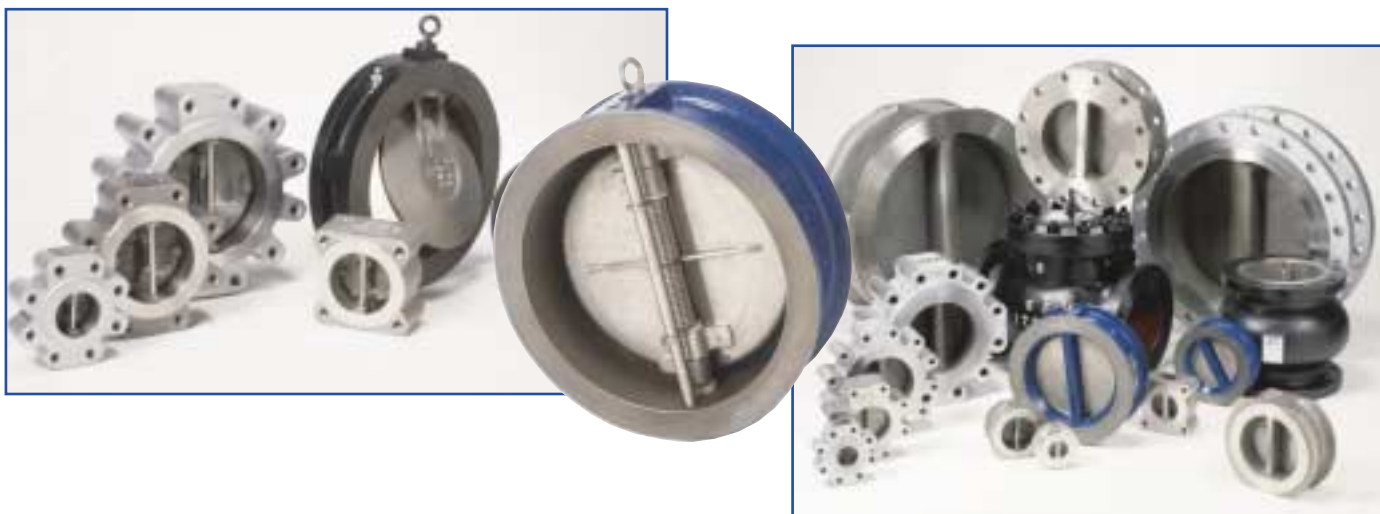

Range of Valves

- | | | | |
|----------------------|-------------------------------|-------------------|------------------------------|
| Sizes: | • 2" to 72" | Materials: | • Cast or Forged |
| Pressures: | • ANSI Class 125 & 250 | | • Cast Iron, Cast Steel |
| | • ANSI Class 150 to 2,500 | | • Stainless Steel & Bronze |
| | • API 2,000# to 10,000# | Types: | • Flanged |
| Temperatures: | • Minus 400°F. to 1,200°F. | | • Flangeless (Wafer Style) |
| Seating: | • Resilient or Metal to Metal | | • Lug (Drilled or Threaded) |
| | | | • Butt Weld |
| | | | • Hub End (for Clamp Joints) |

Lighter

Wafer check valves are recognized as being substantially lighter in weight than conventional swing check valves of the same size and pressure class.

For example:

6" class 150 swing check weighs 175 lbs.

6" 150 **Sure Flow Check** weighs only 28 lbs.

This weight advantage means that the whole pipework system is lighter, consequently the pipework support structure can also be lighter and installation costs reduced.



Stronger

Lighter weight does not mean, however, that strength has been sacrificed. In fact a **Sure Flow Check** is actually stronger than the equivalent length of pipe. Ribs around the side wall support the flange faces.

The **Sure Flow Check Valve** provides the following important features:

- ◆ Twin plate, flat seat design for efficient sealing.
- ◆ Long leg spring(s) allows the plates to open and close without seat scrubbing.
- ◆ Valves 14" and larger are fitted with patented independent spring(s) as a standard feature.
- ◆ Lower head loss than swing checks above 6".
- ◆ Valves with soft seats have bubble tight closure to API 6D.
- ◆ Valves with metal/hardfaced seats have low leakage in accordance with API 598.
- ◆ Simplicity of installation is a key feature.
- ◆ A wide range of seat options is available.

The strong central rib gives rigidity to the body, protects the mechanism from damage by foreign objects in the flow and also provides a broad seating area for the plate heels.

The pins which support the plates and anchor the spring are substantial in order to withstand the pressures imposed on them by the flow.





If the rib profile and size are reduced or the pins are slimmed down, the valve might not provide the safety margin in operation which is one of the main reasons for having a wafer check valve in the first place.

Compact

Sure Flow Check meets the internationally accepted API 594 standard for steel valves. A 6" class 150 valve has a face to face measurement of just 8-3/4" compared with a swing check valve's 14" face to face dimension. A **Sure Flow Check** fits completely inside the flange bolt PCD and therefore external installation is straightforward.

Non-Slam

Sure Flow Check is a non-slam check valve because it operates on flow cessation, not flow reversal. The normal position of the plates is closed, held against the seat by the unique spring design. As flow begins the heels of the two plates are lifted off the seat face on the central rib.

This cracking pressure is less than 2 psi across most of the range. As flow increases, the plates then pivot against the spring pressure. Since the heels have already lifted off the rib seat there is no scrub or wear, either on the rib, body or plate seating surfaces. A pressure of only 4 psi is required to keep the plates fully open.

When flow stops and that pressure is removed the spring closes the plates. Flow reversal is then stopped by the closed **Sure Flow Check** valve and in fact any back pressure only serves to make the valve seal more tightly.



Tight

The long leg spring design - with a single anchor point - is a unique feature of the **Sure Flow Check** design. Coupled with floating plates for minimum seat wear and the right choice of seat to suit the service requirements, this gives the best combination to meet API 598 requirements.

The long spring leg ensures closing tension is applied to the right part of the plate whilst allowing the plate heels to float on opening. For valves 14" and larger, the spring is anchored to the stop pin to ensure that both plates open and close independently. If the spring is not anchored, then the opening of one plate transfers pressure through the spring to make it more difficult for the other plate to open.

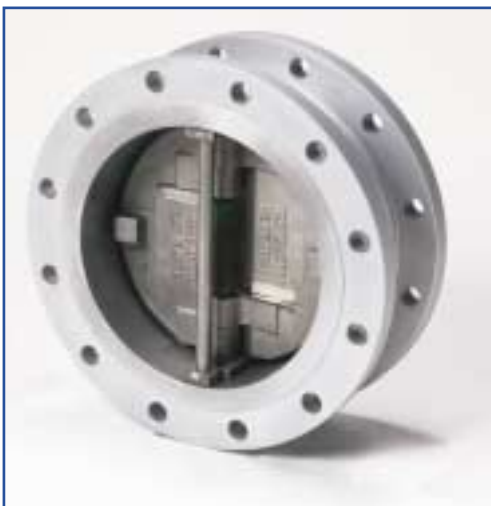

Standard Materials of Construction

ANSI 150 through 2500
Series Body &
Plate Castings

ASTM A216 Grade WCB
Carbon Steel (0.22% Carbon Max.)

ASTM A217 Grade CA15
Stainless Steel (410)

ASTM A351 Grade CF8M
Stainless Steel (316)

BS 1400 Grade AB2 Aluminum Bronze
(ANSI 150 & 300 Series)

Other materials available on request.

Valve Parts Explosion

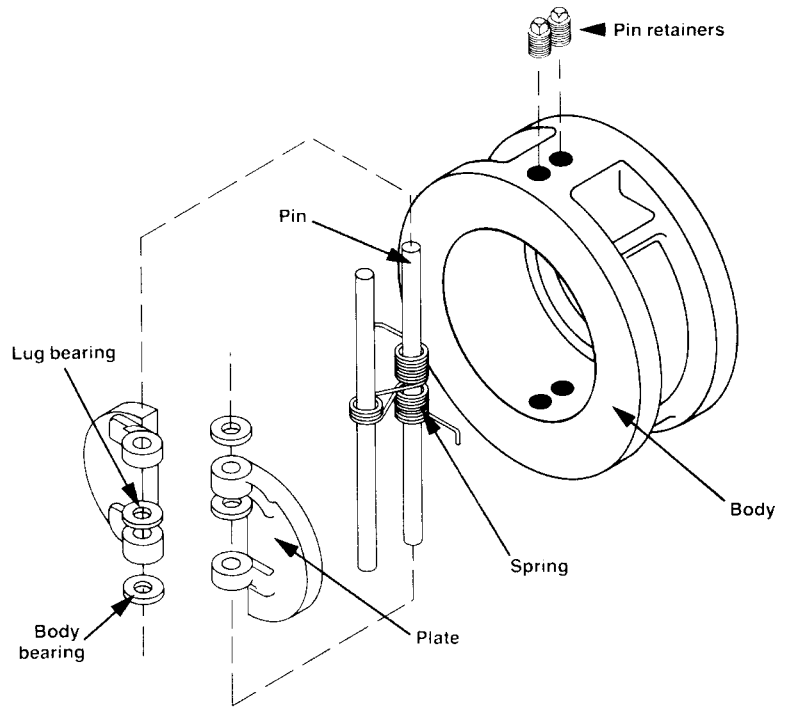

Springs

Max. Operating Temperature

316 SS	120°C (248°F)
Inconel 600	315°C (600°F)
Inconel X 750	537°C (1000°F)

Spring Selection

For temperatures up to 315°C (600°F), Inconel springs will be furnished as standard on all valves that are ordered with metal and Viton seats. For service conditions above 315°C (600°F), Inconel X springs should be specified.

For Seal Selection Refer to Ordering Information

Identification Code/Figure Number

EXAMPLE

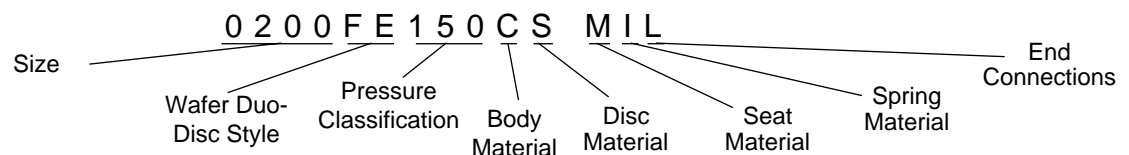

Pressure Classification						
Code	150	300	600	900	1500	2500
ANSI	150	300	600	900	1500	2500

Body and Flapper Materials		
Code	Material	Specification
C	Carbon Steel	ASTM A216 Grade WCB
S	Stainless Steel	ASTM A351 Grade CF8M

Seat Material	
Code	Material
M	Metal
V	Viton

Spring Material		
Code	Material	Max. Temp. F.
I	Inconel	600°F

End Connectors	
Code	Connection
R	Serrated Gasket Finish
L	Lug 2" - 10"
F	Flanged 12" - 24"

Installation Dimensions for ANSI Valves

Class 125 Model FE 125				
Size	Outside Dia.	Face to Face	Min Flange Bore	Weight lbs
2"	4 ¹ / ₈	2 ¹ / ₈	2 ¹ / ₁₆	4.5
3"	5 ³ / ₈	2 ¹ / ₄	3 ¹ / ₁₆	6.5
4"	6 ⁷ / ₈	2 ¹ / ₂	4	10
6"	8 ³ / ₄	3	6 ¹¹ / ₁₆	20
8"	11	3 ³ / ₄	7 ³¹ / ₃₂	35
10"	13 ³ / ₈	4 ¹ / ₄	10	62
12"	16 ¹ / ₈	5 ⁵ / ₈	11 ¹⁵ / ₁₆	105
14"	17 ³ / ₄	7 ¹ / ₄	12 ¹ / ₂	180
16"	20 ¹ / ₄	7 ¹ / ₂	15	253
18"	21 ⁵ / ₈	8	16 ⁷ / ₈	300
20"	23 ⁷ / ₈	8 ³ / ₈	18 ¹³ / ₁₆	355
24"	28 ¹ / ₄	8 ³ / ₄	22 ⁵ / ₈	550

Class 150 Model FE 150				
Size	Outside Dia.	Face to Face	Min Flange Bore	Weight lbs
2"	4 ¹ / ₈	2 ³ / ₈	1 ¹⁵ / ₁₆	5 ¹ / ₂
2 ¹ / ₂ "	4 ⁷ / ₈	2 ³ / ₈	2 ⁵ / ₁₆	8
3"	5 ³ / ₈	2 ⁷ / ₈	2 ²⁹ / ₃₂	12
4"	6 ⁷ / ₈	2 ⁷ / ₈	3 ⁵³ / ₆₄	15
6"	8 ³ / ₄	3 ⁷ / ₈	5 ⁴⁹ / ₆₄	30
8"	11	5	7 ⁵ / ₈	64
10"	13 ³ / ₈	5 ³ / ₄	9 ⁹ / ₁₆	104
12"	16 ¹ / ₈	7 ¹ / ₈	11 ³ / ₈	188
14"	17 ³ / ₄	7 ¹ / ₄	12 ¹ / ₂	214
16"	20 ¹ / ₄	7 ¹ / ₂	15	353
18"	21 ⁵ / ₈	8	16 ⁷ / ₈	400
20"	23 ⁷ / ₈	8 ⁵ / ₈	18 ¹³ / ₁₆	540
24"	28 ¹ / ₄	8 ³ / ₄	22 ⁵ / ₈	875

Class 300 Model FE 300				
Size	Outside Dia.	Face to Face	Min Flange Bore	Weight lbs
2"	4 ³ / ₈	2 ³ / ₈	1 ¹⁵ / ₁₆	6
3"	5 ⁷ / ₈	2 ⁷ / ₈	2 ²⁹ / ₃₂	14
4"	7 ¹ / ₈	2 ⁷ / ₈	3 ⁵³ / ₆₄	15
6"	9 ⁷ / ₈	3 ⁷ / ₈	5 ⁴⁹ / ₆₄	42
8"	12 ¹ / ₈	5	7 ⁵ / ₈	78
10"	14 ¹ / ₄	5 ³ / ₄	9 ⁹ / ₁₆	112
12"	16 ⁵ / ₈	7 ¹ / ₈	11 ³ / ₈	195
14"	19 ¹ / ₈	8 ³ / ₄	12 ¹ / ₂	390
16"	21 ¹ / ₄	9 ¹ / ₈	14 ⁵ / ₁₆	410
18"	23 ¹ / ₂	10 ³ / ₈	16 ⁷ / ₈	660
20"	25 ³ / ₄	11 ¹ / ₂	17 ¹⁵ / ₁₆	810
24"	30 ¹ / ₂	12 ¹ / ₂	21 ⁹ / ₁₆	1300

Class 600 Model FE 600				
Size	Outside Dia.	Face to Face	Min Flange Bore	Weight lbs
2"	4 ³ / ₈	2 ³ / ₈	1 ¹⁵ / ₁₆	6
3"	5 ⁷ / ₈	2 ⁷ / ₈	2 ²⁹ / ₃₂	14
4"	7 ⁵ / ₈	3 ¹ / ₈	3 ⁵³ / ₆₄	18
6"	10 ¹ / ₂	5 ³ / ₈	5 ⁴⁹ / ₆₄	73
8"	12 ⁵ / ₈	6 ¹ / ₂	7 ⁵ / ₈	150
10"	15 ³ / ₄	8 ³ / ₈	9 ⁹ / ₁₆	230
12"	16 ¹ / ₂	9	11 ³ / ₈	319
14"	19 ³ / ₈	10 ³ / ₄	12 ¹ / ₂	435
16"	22 ¹ / ₄	12	14 ⁵ / ₁₆	635
18"	24 ¹ / ₈	14 ¹ / ₄	16 ¹ / ₈	890
20"	26 ⁷ / ₈	14 ¹ / ₂	17 ¹⁵ / ₁₆	1410
24"	31 ¹ / ₈	17 ¹ / ₄	21 ⁹ / ₁₆	2040

Installation Dimensions for Lug Body and Flanged Body ANSI Check Valves

Model FE150 Lug

Class 150				
Size	Outside Diameter	Face to Face	Minimum Flange Bore	Wt. Lbs.
2"	4 3/4	2 3/8	2	9
3"	6	2 7/8	3	18
4"	7 1/2	2 7/8	3 7/8	33
6"	9 1/2	3 7/8	5 7/8	53
8"	11 3/4	5	7 5/8	130
10"	14 1/2	5 3/4	9 5/8	216

Model FE150 Flanged

Class 150				
Size	Outside Diameter	Face to Face	Minimum Flange Bore	Wt. Lbs.
12"	19	7 1/8	11 3/8	279
14"	21	7 1/4	12 1/2	319
16"	23 1/2	7 1/2	15	387
18"	25	8	16 7/8	460
20"	27 1/2	8 5/8	18 7/8	600
24"	32	8 3/4	22 5/8	862
30"	38 3/4	12	29 1/4	1,750
36"	46	14 1/2	35	2,525
42"	53	17	41	4,220

Model FE300 Lug

Class 300				
Size	Outside Diameter	Face to Face	Minimum Flange Bore	Wt. Lbs.
2"	5	2 3/8	2	18
3"	6 5/8	2 7/8	3	33
4"	7 7/8	2 7/8	3 7/8	55
6"	10 5/8	3 7/8	5 7/8	99
8"	13	5	7 5/8	143
10"	15 1/4	5 3/4	9 5/8	233

Model FE300 Flanged

Class 300				
Size	Outside Diameter	Face to Face	Minimum Flange Bore	Wt. Lbs.
12"	20 1/2	7 1/8	11 3/8	336
14"	23	8 3/4	12 1/2	431
16"	25 1/2	9 1/8	14 3/8	675
18"	28	10 3/8	16 1/8	850
20"	30 1/2	11 1/2	17 7/8	1,078
24"	36	12 1/2	22 1/8	1,965
30"	43	14 1/2	28 3/4	3,525
36"	50	19	34	4,700
42"	50 3/4	22 3/8	41	9,750

Model FE600 Lug

Class 600				
Size	Outside Diameter	Face to Face	Minimum Flange Bore	Wt. Lbs.
2"	5	2 3/8	2	18
3"	6 5/8	2 7/8	3	33
4"	8 1/2	3 1/8	3 7/8	86
6"	11 1/2	5 3/8	5 7/8	172
8"	13 3/4	6 1/2	7 5/8	312
10"	17	8 3/8	9 5/8	515

Model FE600 Flanged

Class 600				
Size	Outside Diameter	Face to Face	Minimum Flange Bore	Wt. Lbs.
12"	22	9	11 3/8	550
14"	23 3/4	10 3/4	12 1/2	846
16"	27	12	14 3/8	1,010
18"	29 1/4	14 1/4	16 1/8	1,320
20"	32	14 1/2	18	1,700
24"	37	17 1/2	21 3/8	2,580
30"	44 1/2	19 7/8	28 3/4	5,390
36"	51 3/4	25	33 3/4	10,450
42"	55 1/4	27 5/8	39 1/2	11,700

ANSI Stud Bolting

Valve Size	Class 125				Class 150				Class 300				Class 600				Class 900				Class 1500				Class 2500			
2	4	5/8	5 1/4	4	5/8	5 1/2	6	8	5/8	5 3/4	6 3/4	8	5/8	6 1/2	7	8	7/8	8 1/2	8 3/4	8	7/8	8 1/2	8 3/4	8	1	9 3/4	10	
3	4	5/8	5 3/4	4	5/8	6 1/2	7	8	3/4	7	8	8	3/4	7 3/4	8 1/4	8	7/8	9	9 1/4	8	1 1/8	10 1/4	10 1/2	8	1 1/4	12	12 1/4	
4	8	5/8	6 1/4	8	5/8	6 1/2	7	8	3/4	7 1/4	8 1/4	8	7/8	9 1/4	9 1/2	8	1 1/8	10 3/4	11	8	1 1/4	11 3/4	12	8	1 1/2	14	14 1/2	
6	8	3/4	7	8	3/4	7 3/4	8 1/4	12	3/4	8 3/4	9 3/4	12	1	12	12 1/2	12	1 1/8	14	14	12	1 3/8	16 1/2	16 3/4	8	2	20	20 1/2	
8	8	3/4	8	8	3/4	9 1/4	9 3/4	12	7/8	10 1/2	11 1/4	12	1 1/8	14 1/4	14 1/2	12	1 3/8	16 3/4	17 1/4	12	1 5/8	19 1/2	20	12	2	23 1/4	24	
10	12	7/8	9	12	7/8	10 1/2	11	16	1	12	12 3/4	16	1 1/4	16 3/4	17 1/4	16	1 3/8	18 3/4	19	12	1 7/8	23 1/4	23 1/2	12	2 1/2	29 1/2	30 1/4	
12	12	7/8	10 1/2	12	7/8	11 3/4	12 1/4	16	1 1/8	13 3/4	14 3/4	20	1 1/4	17 3/4	18	20	1 3/8	21 1/2	21 3/4	16	2	27	27 1/2	12	2 3/4	33 1/2	34 1/2	
14	12	1	12	12	1	12 1/4	13 1/4	20	1 1/8	16 1/4	16 1/4	20	1 3/8	20	20	-	-	-	-	-	-	-	-	-	-	-	-	-
16	16	1	13 1/4	16	1	13 1/4	14 1/2	20	1 1/4	16 3/4	16 3/4	20	1 1/2	22 1/2	22 1/2	-	-	-	-	-	-	-	-	-	-	-	-	-
18	16	1 1/8	14	16	1 1/8	14	15 1/4	24	1 1/4	19	19	20	1 5/8	24 1/2	24 1/2	-	-	-	-	-	-	-	-	-	-	-	-	-
20	20	1 1/8	14 1/4	20	1 1/8	14 1/2	15 1/2	24	1 1/4	20 1/4	21 1/4	24	1 5/8	26	27	-	-	-	-	-	-	-	-	-	-	-	-	-
24	20	1 1/4	16 1/2	20	1 1/4	16 3/4	16 3/4	24	1 1/2	22 1/2	22 1/2	24	1 7/8	30 1/2	30 1/2	-	-	-	-	-	-	-	-	-	-	-	-	-

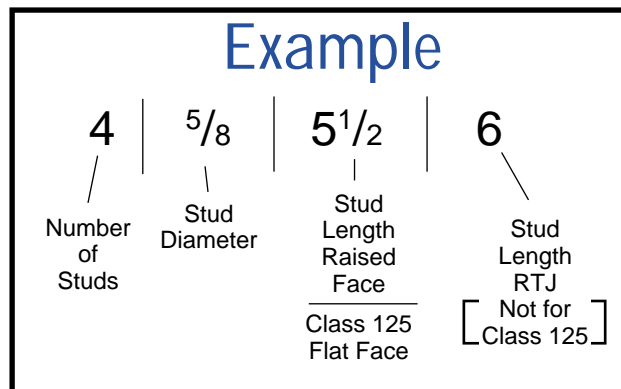

Installation Data

The Sure Flow Check valve is designed so that it is centralized between the flanges when the stud bolts are in position. The outside diameter of the body is equal to the bolt circle PCD minus the diameter of one bolt.

It is suitable for use in a variety of orientations. In horizontal lines the valve is installed with the pins vertical (i.e. with the pin retainers at the top). For sizes 6" and upwards the valve is tapped to take an eyebolt for lifting.

Arrows cast into the body indicate the normal direction of flow.

Before initial installation it is advisable to open the plates by hand since, if the valve is held in store for a period of time, the corrosion inhibitor may have caused the plates to stick to the body and line pressure may not be sufficient to break this seal.

If the bottom half of the studs are installed first they will serve as a platform to support the valve whilst the gaskets and other studs are put in. Similarly, if the valve is to be removed from the line, the top half of the studs should be removed and the bottom half slackened.

Pressure Loss Through Valves

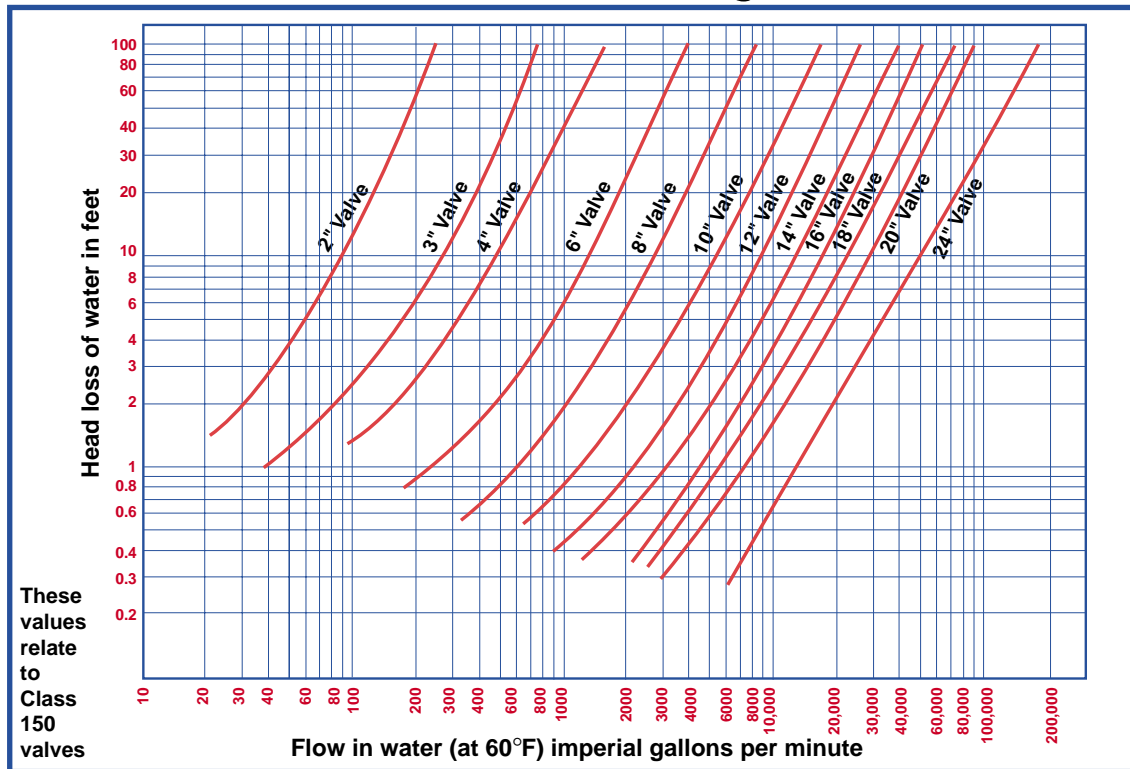

- ◆ We will provide valves to match your performance requirements
- ◆ The curves shown above relate to valves provided with standard rated springs
- ◆ Higher value springs may be required to ensure faster reaction if very large changes in velocity occur
- ◆ It should be borne in mind that a media (liquid) velocity in the pipeline of 10 ft per second is considered to be desirable for normal applications

**Percent of Flow Area
Sure Flow Check vs Standard Steel Pipe**

Size	Pressure Class					
	150	300	600	900	1500	2500
2"	36.7	36.7	44.0	54.4	54.4	36.1
3"	39.1	39.1	43.8	46.6	46.6	32.8
4"	41.4	41.4	45.8	47.7	47.7	29.5
6"	54.0	54.0	58.5	52.9	52.9	33.4
8"	56.7	56.7	57.8	58.6	58.6	32.7
10"	56.0	56.0	67.9	70.5	52.6	30.9
12"	61.8	61.8	63.0	71.8	62.0	31.2
14"	66.7	72.5	62.9	75.4	75.4	—
16"	64.3	55.2	67.9	71.8	71.8	—
18"	74.5	69.9	64.8	76.4	74.0	—
20"	70.8	65.1	67.4	84.0	81.0	—
24"	66.0	63.4	68.3	71.4	71.0	—

Approximate performance data for Sure Flow Check valves when used with water at 60° F with a nominal 10 ft/sec velocity

Valve Size	Flow (imperial gals/min)	Pressure drop psi	Head loss in feet	Approx. equiv. length of pipe in feet
2"	86	4.49	10.32	30
3"	192	2.97	6.83	34
4"	368	2.30	5.29	35
6"	750	1.47	3.38	37
8"	1292	1.20	2.76	40
10"	2116	0.93	2.14	41
12"	2920	0.81	1.87	44
14"	3570	0.74	1.70	45
16"	4750	0.60	1.38	47
18"	6600	0.55	1.27	47
20"	7500	0.51	1.18	50
24"	12500	0.42	0.97	52

Seat Options

The right seat is critical for the correct functioning of the valve in its designated service. **Sure Flow Check** offers a wide range of seat options.

Metal to metal seats can be either the body/plate parent material or a hardfacing of other material, overlaid by deposition.

For soft seated valves standard elastomers are vulcanized for maximum security.

On high pressure class valves it is set into a groove for further safety.

Simple Installation

Simplicity and speed of installation are of paramount importance for the process or pipeline engineer. **Sure Flow Check** is simply installed between the flanges. A raised face (serrated or smooth finish), an RTJ, profile hub and butt weld ends can be provided. Only one set of studs is required as **Sure Flow Check** fits inside the bolt circle PCD. If the valve needs to be taken out of the line, only half the bolts need to be removed, reducing the amount of work to be done and providing a retained link for the two pipe flanges.

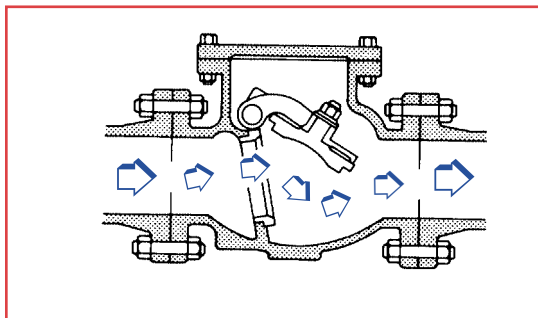

Conventional swing check valve

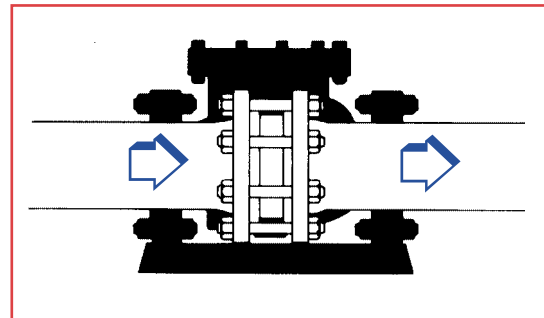

Horizontal Flow - rib vertical

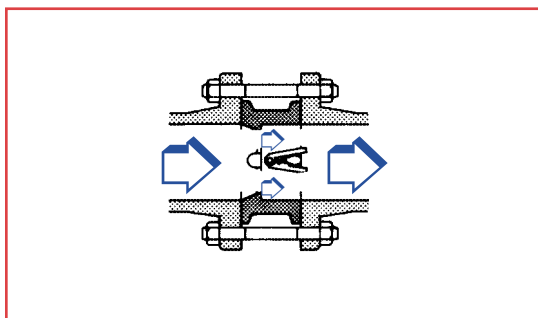

Sure Flow Check dual plate wafer check valve

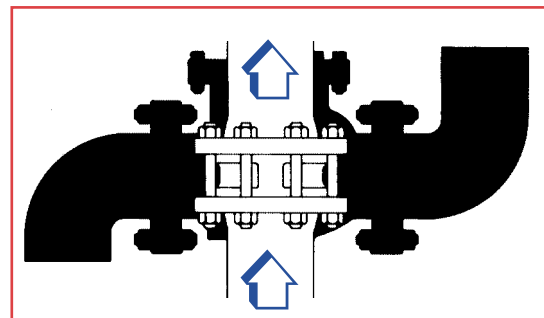

Vertical Flow

Quality From Start To Finish

Quality Counts

Our quality starts with design and engineering, continues through development and testing, to manufacture and certification. Our technical and sales support services are vital ingredients in maintaining the overall quality of our products. The stringent quality control, inspection and testing procedures we apply are contained within the Documented Quality System.

*Manufactured to API 594
and tested to API 598*

Quality is manufactured not inspected

Our operatives are responsible for the quality and accuracy of their work and for ensuring that it is in accordance with the appropriate working drawings and specifications. Our Q.A. Department checks initial compliance throughout all aspects of manufacture from the receipt of materials to the end of the machining process.

Our Quality Assurance Department remains the ultimate authority in guaranteeing that materials, engineering and methods are in full accordance with agreed specifications and established procedures. Through a combination of these procedures we can confidently fulfil all requirements for material conformity and traceability and for full certification.

When you specify **Sure Flow Check** valves, you can be confident that not only are you making an investment in quality and reliability, but equally important, you know the service starts with the sale.

*All requirements for
material conformity,
traceability and
certification met in full*



Type CD 150 - VIR - Wafer - Double Door - Dual Disc - Metal Hinge Check Valve



The **Eco (Economical) Dual Plate**, Metal Hinged check valve features ease of maintenance and exceptional flow characteristics.

- Body gives compact, wafer design
- Dual plate valves give maximum strength with minimum opening time
- Full contact seats maintain positive shut-off at minimum working pressure
- Torsion springs assist valve closure, preventing flow reversal
- Shaft is of extra heavy duty, corrosion resistant construction
- Shaft supports with large bearings act as stops to prevent over travel of plates
- Thrust washers reduce friction and wear of valve plate hinges.
- **Model CD150CS-VIR Carbon Steel Body/316SS Discs**
- **Model CD150SS-VIR 316SS Body**

Operating Pressures and Temperatures

Service	Size	psi	Temp
W.O.G.	2" - 12"	285	100°F

Construction

No	Name	Material	Qty
1	Seat/Seal	Viton	1
2	Disc	ASTM A351 CF8M	2
3	Shaft	316 Stainless Steel	2
4	Plugs	A105/A182	4
5	Washer	316 Stainless Steel	2
6	Torsion Spring	316 Stainless Steel	2
7	Cast Body	ASTM A216 WCB/ASTM A351 CF8M	1

Dimensional Data

Size	Model	A	B	C	D	E	Shipping Weight (lbs)
2	0200CD150	2 3/8	4 1/8	2 3/8	1/8	1 9/16	6
2 1/2	0250CD150	2 3/8	4 7/8	3 1/2	3/8	2 1/2	8
3	0300CD150	2 7/8	5 3/8	3 1/2	3/8	2 1/2	12
4	0400CD150	2 7/8	6 7/8	4 1/2	7/8	3 1/4	15
6	0600CD150	3 7/8	8 3/4	7	1 1/2	5 1/4	30
8	0800CD150	5	11	8 5/8	2 1/8	6 3/4	64
10	1000CD150	5 3/4	13 3/8	10 3/4	2 3/4	8 3/4	104
12	1200CD150	7 1/8	16 1/8	13 1/2	3	10 1/2	188

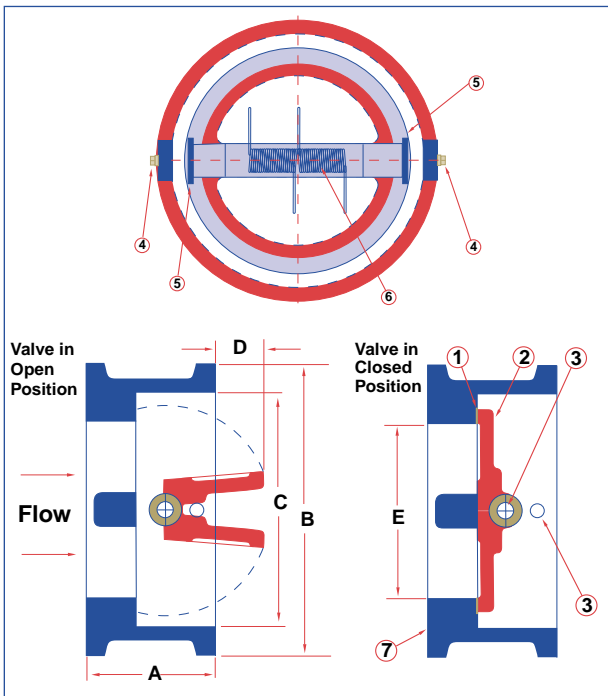

Ordering Information

Example: Include full description

Size (Prefix) Model #

0400 - CD150SS-VIR

4", 316SS Body Wafer Check Valve, Viton Seat, 316SS Discs.

Notes

Manufacturer reserves the right to modify dimensions, materials, or design. Contact factory for certification.

Valves are designed to operate on vertical and horizontal flow, see note 1.

NOTE 1

Horizontal Flow: Valve must be installed with disc hinge pin in the vertical position, to insure proper operation.



Type CC125, CD125-IS Wafer - Double Door - Dual Disc - Metal Hinge Check Valve



The **Eco (Economical) Dual Plate**, Metal Hinged check valve features ease of maintenance, exceptional flow characteristics.

- Body gives compact, one-piece wafer design
- Dual plate valves give maximum strength with minimum opening time
- Full contact seats maintain positive shut-off at minimum working pressure
- Torsion springs assist valve closure, preventing flow reversal
- Shaft is of extra heavy duty, corrosion resistant construction
- Shaft supports with large bearings act as stops to prevent over travel of plates
- Thrust washers reduce friction and wear of valve plate hinges.
- **Model CD125-IS with 316SS Disc**

Operating Pressures and Temperatures

Service	Size	psi	Temp
W.O.G.	2" - 48"	200	200°F

Construction

No	Name	Material	Qty
1	Seat/Seal	Buna-N	1
2	Disc	ASTM A351 CF8M	2
3	Shaft	316 Stainless Steel	2
4	Plugs	A105/A182	4
5	Washer	316 Stainless Steel	2
6	Torsion Spring	316 Stainless Steel	2
7	Cast Body	ASTM A126 GR B	1

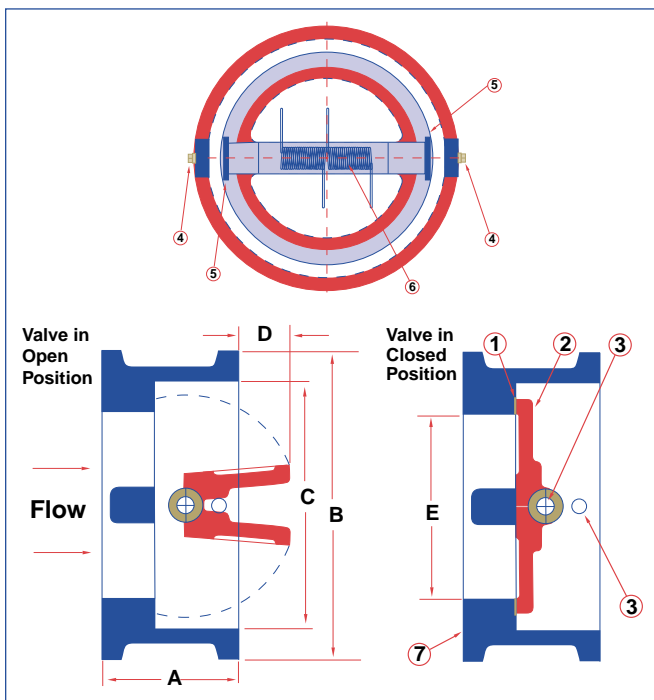

Dimensional Data

Size Inches	Model	A	B	C	D	CV	Shipping Weight (lbs)
2	0200	2 1/8	4 1/8	2 9/16	3/16	80	6
2 1/2	0250	2 1/8	4 7/8	3 1/16	3/8	90	7
3	0300	2 1/4	5 3/8	3 3/4	5/8	150	10
4	0400	2 1/2	6 3/8	4 5/8	7/8	300	14
5	0500	2 3/4	7 3/4	5 7/8	1 5/16	500	19
6	0600	3	8 11/16	6 11/16	1 5/8	900	25
8	0800	3 3/4	11	8 3/4	2 1/4	1,700	40
10	1000	4 1/4	13 3/8	10 15/16	3	3,000	70
12	1200	5 5/8	16 1/8	12 7/8	3 3/16	4,000	100
14	1400	7 5/16	17 3/4	14 1/4	3 3/4	5,350	140
16	1600	7 5/8	20 1/4	16 5/16	3 3/4	7,400	180
18	1800	8 1/16	21 5/8	18 3/8	4 1/4	10,000	250
20	2000	8 1/2	23 7/8	20 1/4	5 3/8	13,000	300
24	2400	8 7/8	28 1/4	24	8 1/4	24,000	420
36	3600	9 1/2	40	36 1/2	13 1/8	62,000	1200
40	4000	11 7/8	44 1/2	40 1/2	13 1/8	90,000	1800
48	4800	13 7/8	53	48 1/2	17 1/2	130,000	3000

Ordering Information

Example: Include full description

Size (Prefix) Model #

0400 - CD125IS

4", Cast Iron Wafer Check Valve,
 Buna Seat, 316SS Discs.

Notes

Manufacturer reserves the right to modify dimensions, materials, or design. Contact factory for certification.

Valves are designed to operate on vertical and horizontal flow, see note 1.

NOTE 1

Horizontal Flow: Valve must be installed with disc hinge pin in the vertical position, to insure proper operation.



Type CXF-125 Flanged Elastic Swing Check Valve



The **Elastic Swing Check Valve** is suitable for municipal and industrial applications.

It is standard with a ductile iron body with flanges which comply with ANSI B16.1; Class 125 or 250. The internal body is epoxy coated. Special coatings are available upon request. The one-piece molded disc has a steel reinforced insert to insure closure. Plus, while in the open position, it will allow 100% uninterrupted flow. The one-piece disc hinge and flapper can be repaired without removal of the valve from the line.

The elastic check can be installed in a vertical or horizontal pipeline.

Construction

No	Name	Material	Qty
1	Body	ASTM A536 60-45-12	1
2	Cover	ASTM A536 60-45-12	1
3	Disc	Viton w/steel & fabric reinforcement	1
4	Gasket	Lexide NK-511 (non asbestos)	1
5	Cover Bolts	Alloy steel SAE Grade S	4
6	Drain	ASTM A536 60-45-12	1

*Face to face: ANSI B16.10

*Flanged End: ANSI B16.1 BS4505 PN16

Operating Pressures and Temperatures

Service	Size	psi	Temp
W.O.G.	2" - 12"	200	150°F
	14" - 24"	150	150°F

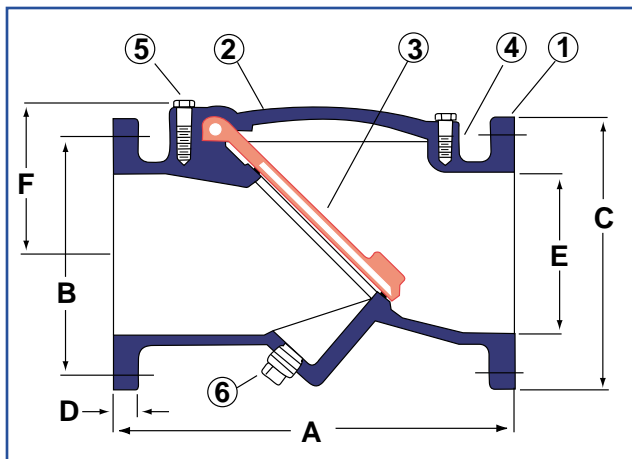

Dimensional Data

Size Inches	Model	A	B	C	D	E	F	Drain Size	Shipping Weight (lbs)
2	0200CXF125IV	8	4 3/4	6	5/8	2	3 3/8	3/4	30
2 1/2	0250CXF125IV	8 1/2	5 1/2	7	11/16	2 1/2	3 3/8	3/4	38
3	0300CXF125IV	9 1/2	6	7 1/2	3/4	3	3 7/8	3/4	46
4	0400CXF125IV	11 1/2	7 1/2	9	15/16	4	4 5/8	1	70
5	0500CXF125IV	13 3/4	8 1/2	10	15/16	5	5 1/8	1	100
6	0600CXF125IV	15	9 1/2	11	1	6	5 7/8	1 1/4	115
8	0800CXF125IV	19 1/2	11 3/4	13 1/2	1 1/8	8	7 5/8	1 1/2	250
10	1000CXF125IV	24 1/2	14 1/4	16	1 3/16	10	9 7/8	2 1/2	525
12	1200CXF125IV	27 1/2	17	19	1 1/4	12	11 1/2	2 1/2	710
14	1400CXF125IV	31	18 3/4	21	1 3/8	14	13 1/2	2 1/2	860
16	1600CXF125IV	31 15/16	21 1/4	23 1/2	1 7/16	16	15 1/4	2 1/2	1090
18	1800CXF125IV	35 15/16	22 3/4	25	1 9/16	18	17 1/4	3	1450
20	2000CXF125IV	39 15/16	25	27 1/2	1 11/16	20	19 1/4	3	1575
24	2400CXF125IV	47 15/16	29 1/2	32	1 7/8	24	22 3/4	3	2600

Ordering Information

Example: Include full description

Size (Prefix) Model #
0400 - CXF125IV

4", Ductile Iron Flanged Check Valve,
 Viton Seat, 316SS Disc.



Notes

Manufacturer reserves the right to modify dimensions, materials, or design. Contact factory for certification.

Type CSF-125IB Flanged Horizontal Swing Check Valve



The **Sure Flow Horizontal Swing** Check Valve has a cast iron body, cover and disc. The valve is provided with a bronze seat ring and bronze disc ring.

Bronze being softer than a cast iron facing, it offers a more positive sealing effect than competitors' standard iron facing. At the same time, a bronze seat ring and disc ring is very versatile in its stability to temperature and various commonly handled materials.

Conforming to MSS SP-71

End Flange Dimensions: ANSI B16.1

Face to Face Dimensions: ANSI B16.10.

Construction

No	Name	Material
1	Cover Bolt & Nut	Steel
2	Cover	ASTM A126 Class B
3	Gasket	Graphite
4	Hanger Pin	Stainless Steel
5	Hanger	ASTM A126 Class B
6	Disc Ring	ASTM B62
7	Disc	ASTM A126 Class B
8	Disc Washer	Steel
9	Disc Bolt	Steel
10	Seat Ring	ASTM B62
11	Body	ASTM A126 Class B

Operating Pressures and Temperatures

Service	Size	psi	Temp
W.O.G.	2" - 48"	200	200°F

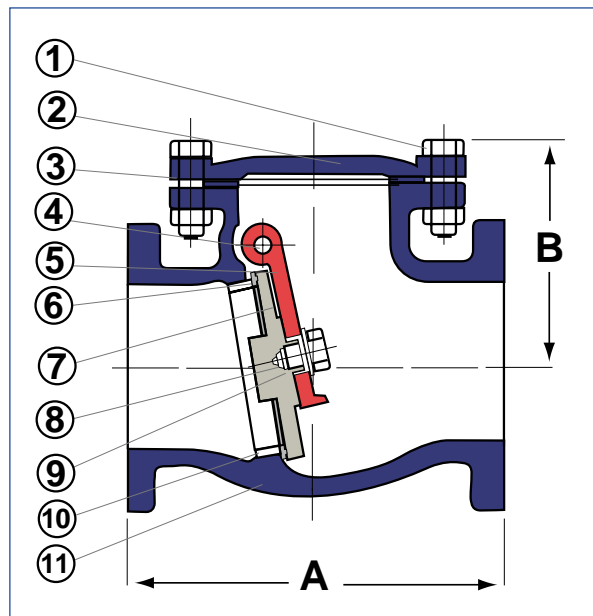

Notes

Manufacturer reserves the right to modify dimensions, materials, or design. Contact factory for certification.

Dimensional Data

Size Inches	Model	A	B	Shipping Weight (lbs)
2	0200CSF125IB	8	5 1/8	20
2 1/2	0250CSF125IB	8 1/2	5 5/8	25
3	0300CSF125IB	9 1/2	6 1/8	30
4	0400CSF125IB	11 1/2	7 1/8	70
5	0500CSF125IB	13	9	88
6	0600CSF125IB	14	9 1/4	98
8	0800CSF125IB	19 1/2	10 7/8	130
10	1000CSF125IB	24 1/2	12 1/4	300
12	1200CSF125IB	27 1/2	13 3/4	410
14	1400CSF125IB	31	17	496
16	1600CSF125IB	36	18 5/8	660
18	1800CSF125IB	38	21	825
20	2000CSF125IB	42	23	981
24	2400CSF125IB	46	26 1/2	1476

Ordering Information

Example: Include full description

Size (Prefix) Model #

0400 - CSF125IB

4", Cast Iron Flanged Horizontal Swing Check Valve, Bronze Seat Ring



Type CSW-125IS Wafer Swing Check Valve ANSI 125/150 Class



The **Wafer Swing Check Valve** incorporates several features distinguishing it from conventional check valves for silent, fast, non slam operation. The most prominent of these is the accurately machined clapper and its special quick closing action. Spring loading of the 316SS clapper assures instantaneous closure to reversing flow, preventing build-up of momentum, the cause of damaging water hammer. The hinge pin design assures free movement of the clapper and eliminates seizure under extreme conditions. Soft seat inserts are standard for positive sealing of hard-to-hold solvents and fluids. Lifting eye hook on 8" to 12" valves.

Operating Pressures and Temperatures

Service	Size	psi	Temp
W.O.G.	2" - 12"	285	100°F

Construction

No	Name	Material
1	Seat/Seal	Viton
2	Clapper	ASTM A351 CF8M
3	Arm	316 Stainless Steel
4	Plugs	A105/A182
5	Washer	316 Stainless Steel
6	Torsion Spring	316 Stainless Steel
7	Cast Body	ASTM A126 GR B

Dimensional Data

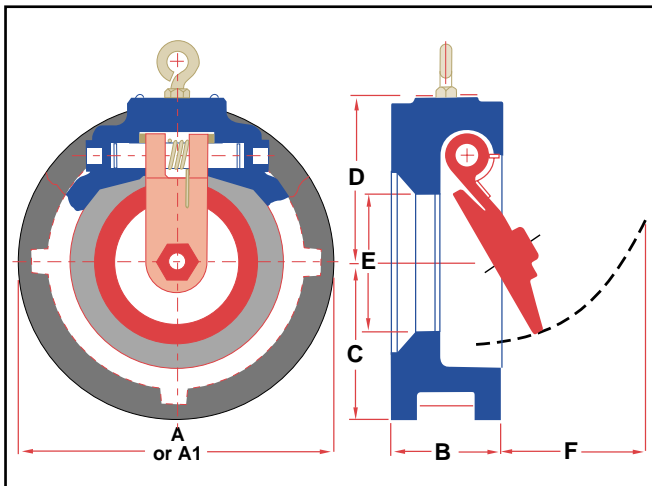

Size Inches	Model	A	B	C	D	E	F	Shipping Weight (lbs)
2	0200CSW125IS	4 1/8	1 3/4	2 1/16	2 1/4	1 17/32	1 1/2	8
2 1/2	0250CSW125IS	4 7/8	1 7/8	2 7/16	2 5/8	1 3/4	1 25/32	10
3	0300CSW125IS	5 3/8	2	2 11/16	3 1/16	2 1/16	2 11/32	14
4	0400CSW125IS	6 7/8	2 1/4	3 7/16	3 5/8	3 3/32	3 1/4	22
5	0500CSW125IS	7 3/4	2 1/2	3 7/8	4 3/8	3 7/8	3 15/16	30
6	0600CSW125IS	8 3/4	2 3/4	4 3/8	4 7/8	4 3/4	5 1/32	44
8	0800CSW125IS	11	2 7/8	5 1/2	6	6 7/16	7 29/32	60
10	1000CSW125IS	13 3/8	3 1/8	6 11/16	6 11/16	7 1/2	8 3/8	96
12	1200CSW125IS	16 1/8	3 3/8	8 1/16	8 3/8	9 1/2	10 1/4	140

Notes

Manufacturer reserves the right to modify dimensions, materials, or design. Contact factory for certification.

Valves are designed to operate on vertical and horizontal flow, see note 1.

NOTE 1

The wafer check valve is designed for installation between two pipe flanges in horizontal or vertical pipelines (in the latter case upward flow is preferred).



Ordering Information

Example: Include full description

Size (Prefix) Model #

0400 - CSW125IS

4", Cast Iron Wafer Swing Check Valve, Viton Seat, 316SS Clapper

Type CW125IS/250 - Cast Iron Flat Face



Operating Pressures and Temperatures:

Service	Size	psi	Temp.
Liquid	2" - 12"	400	180°F

Sure Flow Wafer Check Valves are designed to close before the pump stops completely. This prevents flow reversal which eliminates water hammer and system surges associated with valve closure.

- Quiet Operation
- Guided Discs
- Vertical or Horizontal Installation
- Sizes 2" thru 12"

Service Applications

- Municipal Water Systems
- Industrial Class HVAC - Liquid Service
- Industrial Piping Systems
- Irrigation Systems

Construction

No	Name	Material
1	Body	Cast Iron A-126-B
2	Plug	Cast Bronze B62 <i>or Stainless Steel</i>
3	Spring	Stainless Steel
4	Seat	Cast Bronze B62 <i>or Stainless Steel</i>
5	Bushing	Cast Bronze B62 <i>or Stainless Steel</i>
6	Screw	Stainless Steel

Dimensional Data

Size	Model	A	B	CV	Shipping Weight (lbs)
2	0200CW125IS/250	2 3/4	4 1/4	40	7
2 1/2	0250CW125IS/250	2 7/8	5	60	9
3	0300CW125IS/250	3 1/4	5 3/4	85	15
4	0400CW125IS/250	4	7	150	25
5	0500CW125IS/250	4 5/8	8 3/8	230	32
6	0600CW125IS/250	5 1/2	9 3/4	340	56
8	0800CW125IS/250	5 1/2	11 7/8	600	100
10	1000CW125IS/250	8 1/4	16	900	140
12	1200CW125IS/250	11 1/4	19		370

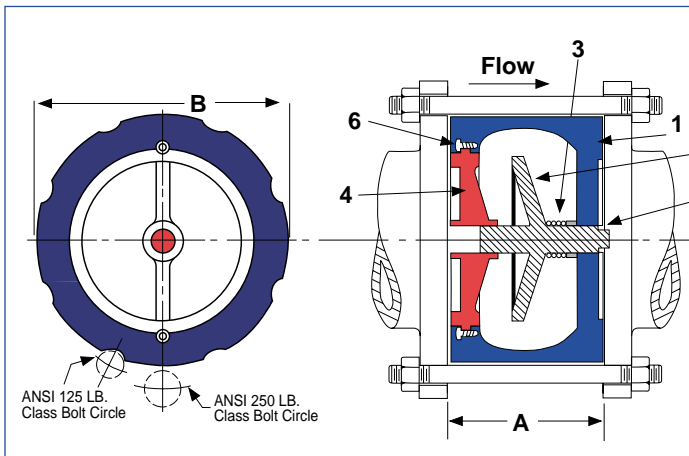

Notes

Manufacturer reserves the right to modify dimensions, materials, or design. Contact factory for certification.

The Flow Coefficient (Cv) is the number of gallons per minute of water flowing through a given size restriction at a pressure drop of one psi. To obtain the Cv factor for a given size check valve refer to table above.



Ordering Information

Example: Include full description

Model # Type & Material

0400 - CW125IS/250

4", Flat Face Wafer Check Valve Silent, Bronze Plug

Consult factory for optional construction materials.
Resilient seating of BUNA-N or VITON available.

Type CW150/300 - Cast Steel & CW150SS/300 Cast Stainless Steel



Operating Pressures and Temperatures:

Service	Size	psi	Temp.
Liquid	2" - 24"	740	100°F

Sure Flow Wafer Check Valves are designed to close before the pump stops completely. This prevents flow reversal which eliminates water hammer and system surges associated with valve closure.

- Quiet Operation
- Guided Discs
- Vertical or Horizontal Installation
- Sizes 2" thru 24"

Service Applications

- Municipal Water Systems
- Industrial Class HVAC - Liquid Service
- Industrial Piping Systems
- Irrigation Systems

Construction - Cast Steel

No	Name	Material
1	Body	Cast Steel A-216WCB
2	Plug	Cast S. Steel A-351
3	Spring	Stainless Steel
4	Seat	Cast S. Steel A-351
5	Bushing	Cast S. Steel A-351
6	Screw	Stainless Steel

Construction - Cast Stainless Steel

All ASTM Spec A351 Grade CF8M Stainless Steel.

Dimensional Data

Size	Model	A	B	CV	Shipping Weight (lbs)
2	0200CW150SS/300	2 5/8	4 7/8	50	7
2 1/2	0250CW150SS/300	3	5 3/4	72	9
3	0300CW150SS/300	3 3/16	6 1/2	92	15
4	0400CW150SS/300	4 1/16	7	180	25
5	0500CW150SS/300	4 7/8	8 7/8	276	32
6	0600CW150SS/300	6 1/2	9 11/16	408	56
8	0800CW150SS/300	6 5/8	11 5/8	720	100
10	1000CW150SS/300	7 1/2	14 5/8	1000	140

* Also Available in size 12", 14", 16", 18", 20" and 24".

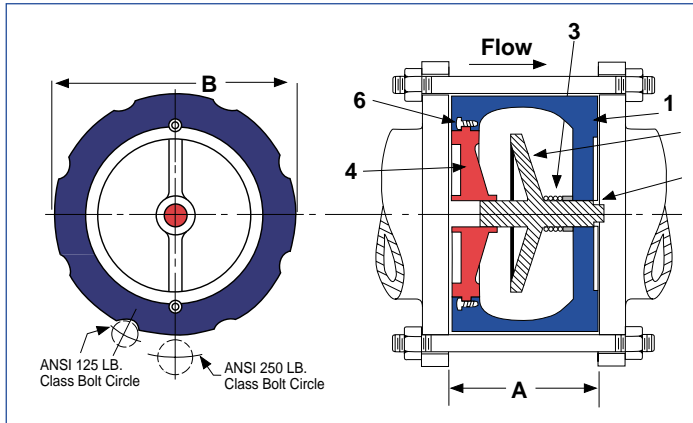

Ordering Information

Example: Include full description

Model # Type & Material

0400 - CW150SS/300

4", Raised Face Wafer Silent Check Valve,
 All 316SS Construction

Consult factory for optional construction materials.
 Resilient seating of BUNA-N or VITON available.

Notes

Manufacturer reserves the right to modify dimensions, materials, or design. Contact factory for certification.

The Flow Coefficient (Cv) is the number of gallons per minute of water flowing through a given size restriction at a pressure drop of one psi. To obtain the Cv factor for a given size check valve refer to table above.



Type CF125 or **CF125IS/C Cast Iron**



Operating Pressures and Temperatures:

Service	Size	psi	Temp.
Liquid	2" - 16"	200	150°F

Sure Flow Globe Style Check Valves are designed to close before the pump stops completely. This prevents flow reversal which eliminates water hammer and system surges associated with valve closure.

- Quiet Operation
- Guided Discs
- Vertical or Horizontal Installation
- Sizes 2" thru 16"

Service Applications

- Municipal Water Systems
- Industrial Class HVAC - Liquid Service
- Industrial Piping Systems
- Irrigation Systems

Construction

No	Name	Material
1	Body	Cast Iron A-126-B
2	Plug	Cast Bronze B62 <i>or Stainless Steel</i>
3	Spring	Stainless Steel
4	Seat	Cast Bronze B62 <i>or Stainless Steel</i>
5	Bushing	Cast Bronze B62 <i>or Stainless Steel</i>
6	Screw	Stainless Steel

Dimensional Data

Size	Model	A CF125IB	A 316SS Plug CF125IS/C	CV	Shipping Weight (lbs)
2	0200CF125	5 1/4	6 1/4	40	30
2 1/2	0250CF125	5 1/2	7	100	34
3	0300CF125	6	7 1/2	130	50
4	0400CF125	7 1/4	8 1/2	225	75
5	0500CF125	8 1/2	9 1/2	340	100
6	0600CF125	9 3/4	10 1/2	540	130
8	0800CF125	12 1/2	13 1/2	830	240
10	1000CF125	15 1/2	16 1/4	1370	360
12	1200CF125	14 1/4	20 1/4	1980	600
14	1400CF125	15 3/4	22 3/4	2300	710
16	1600CF125	17 5/8	24 3/4	3200	810
18	1800CF125		22 1/2	6200	910
20	2000CF125		24	6800	1140
24	2400CF125		24	9800	2600

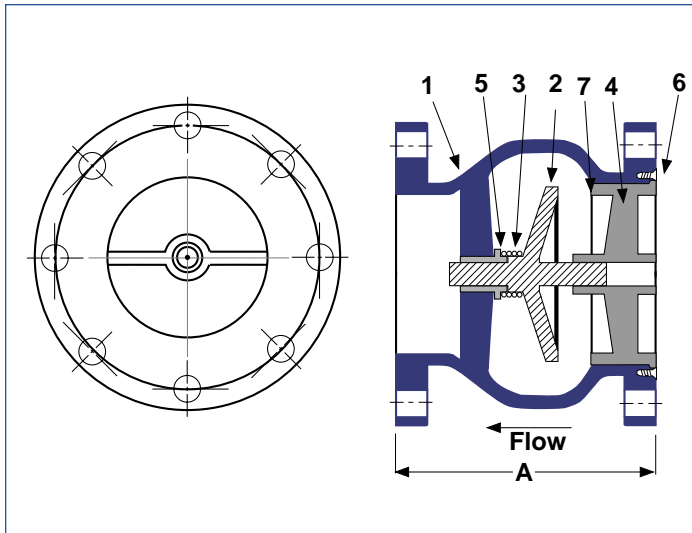

Ordering Information

Example: Include full description

Size (Prefix) **Model #**

0400 - CF125IS/C

4", Flat Face Flanged Cast Iron Silent Check Valve with 316SS Disc

Consult factory for optional construction materials. Resilient seating of BUNA-N or VITON available.

Notes

Manufacturer reserves the right to modify dimensions, materials, or design. Contact factory for certification.

The Flow Coefficient (Cv) is the number of gallons per minute of water flowing through a given size restriction at a pressure drop of one psi. To obtain the Cv factor for a given size check valve refer to table above.



Type CF150 Cast Steel, Type CF150SS Stainless Steel



Sure Flow Globe Style Check Valves are designed to close before the pump stops completely. This prevents flow reversal which eliminates water hammer and system surges associated with valve closure.

- Quiet Operation
- Guided Discs
- Vertical or Horizontal Installation
- Sizes 2" thru 12"

Service Applications

- Municipal Water Systems
- Industrial Class HVAC - Liquid Service
- Industrial Piping Systems
- Irrigation Systems

Construction - Cast Steel

No: 1, 4, 5: Cast Steel
 2, 3, 6: Stainless Steel
 Plug: Standard Stainless Steel

Construction - Cast Stainless Steel

All ASTM Spec A351 Grade CF8M Stainless Steel.

Operating Pressures and Temperatures:

Rating	Size	psi	Temp.
150 LB. CLASS	2" - 12"	285	100°F

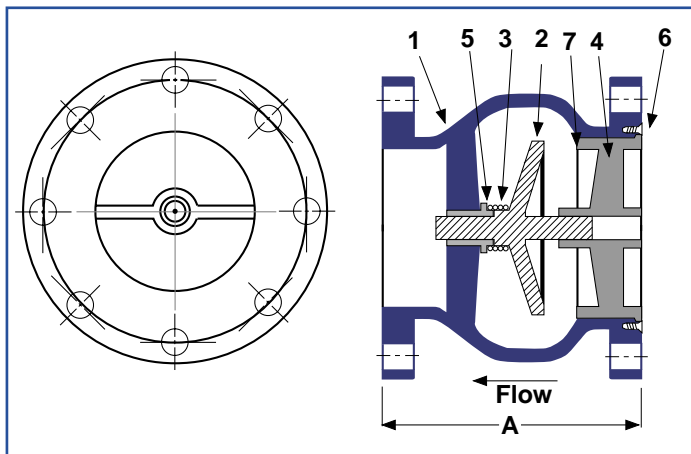

Dimensional Data

Size	Model	A	CV	Shipping Weight (lbs)
2	0200CF150	5 1/4	55	30
2 1/2	0250CF150	5 1/2	90	41
3	0300CF150	7 1/2	140	56
4	0400CF150	8 1/2	265	90
5	0500CF150	8 1/2	420	120
6	0600CF150	10 1/2	610	150
8	0800CF150	12	1000	260
10	1000CF150	15 1/2	1700	410
12	1200CF150	14 1/4	2400	720

Notes

Manufacturer reserves the right to modify dimensions, materials, or design. Contact factory for certification.

The Flow Coefficient (Cv) is the number of gallons per minute of water flowing through a given size restriction at a pressure drop of one psi. To obtain the Cv factor for a given size check valve refer to table above.

Ordering Information

Example: Include full description

Size (Prefix) Model #

0400 - CF150

4", 150# Raised Face Cast Steel - Silent Check Valve

Consult factory for optional construction materials. Resilient seating of BUNA-N or VITON available.



Silent Check Valves

Wafer Style

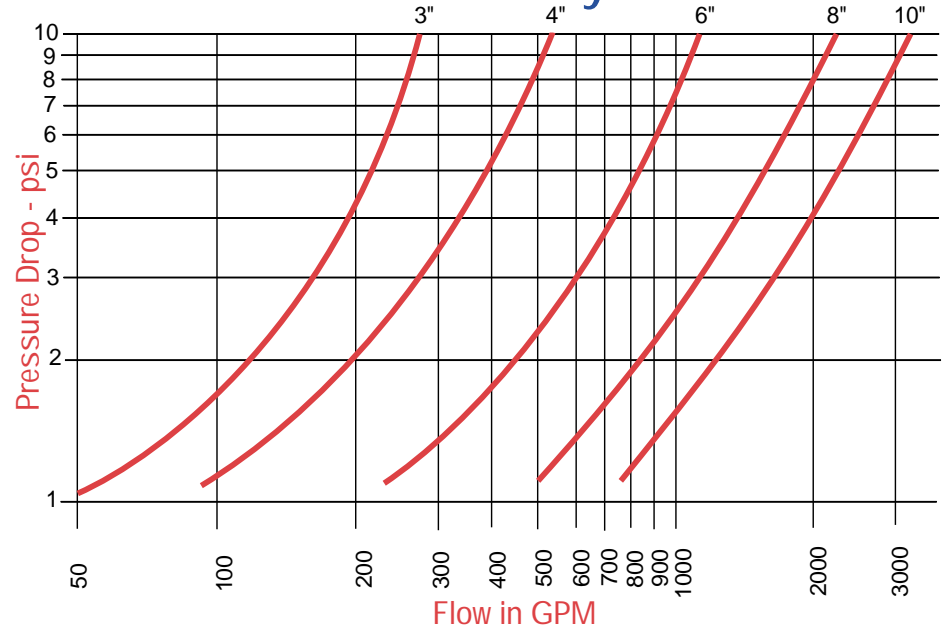

Globe Style

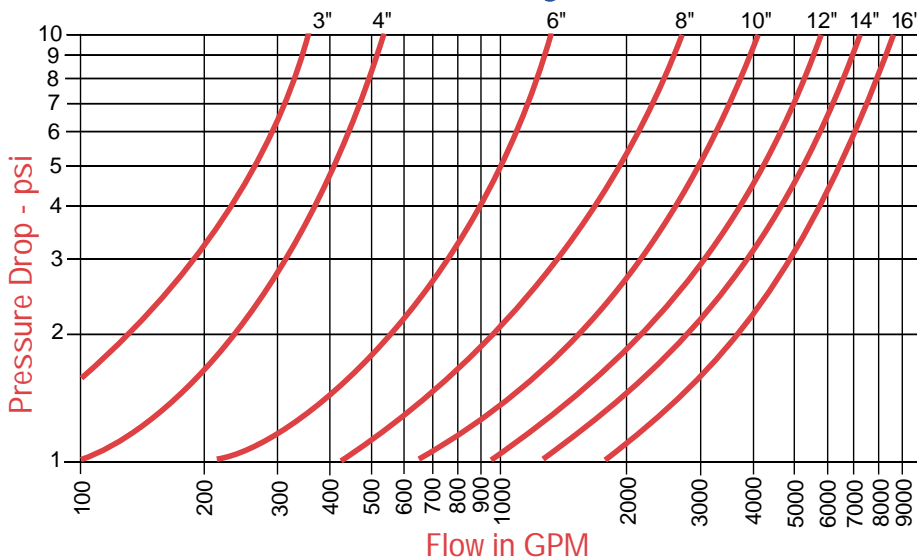

- The above curves are based on the flow of clean water at ambient temperature.
- Preferred piping standards recommend placing check valves 5 to 10 pipe diameters from any turbulence producing device, i.e. pumps, elbows, etc.
- Maximum recommended flow velocity of 10 ft./sec.

Type FV 125 Cast Iron, Type FV150 Cast Steel, Type FV1500SS Stainless Steel Foot Valves



Construction

Design of the [Sure Flow Foot Valve](#), available in sizes 2 inches to 30 inches, evolved through a need for a valve that could provide positive sealing actions at various pressure ranges without seat damages along with silent operation.

The Sure Flow Foot Valve, satisfies these requirements plus low head loss through its full ported area and heavy duty stainless steel basket screening.

The Buna-N o-ring, provides a drop-tight seal. As the pressure increases, the Buna-N o-ring is compressed slightly and the disc makes contact with the metal portion of the valve seat, preventing any further compression of the Buna-N o-ring. The Buna-N o-ring will continue to provide the "drop-tight seating" during the higher pressure ranges without damage from the increased pressure loading.

Standard Features:

- The seating design provides positive shut-off at all pressure ranges without additional loading on the seal.
- Heavy duty stainless steel screening, with flow area 3 to 4 times that of pipe area.
- Silent operation, by design of disc, stroke and linear closing characteristics.
- Cast iron, 125 lb. ANSI Standard.



Optional Features:

- Available in carbon steel & stainless steel

Ordering Information

Example: Include full description

Size (Prefix)	Model #
1200 -	FV150

12", Carbon Steel Flanged Foot Valve

A foot valve should be used with basket strainers and check valves.

Notes

Manufacturer reserves the right to modify dimensions, materials, or design. Contact factory for certification.

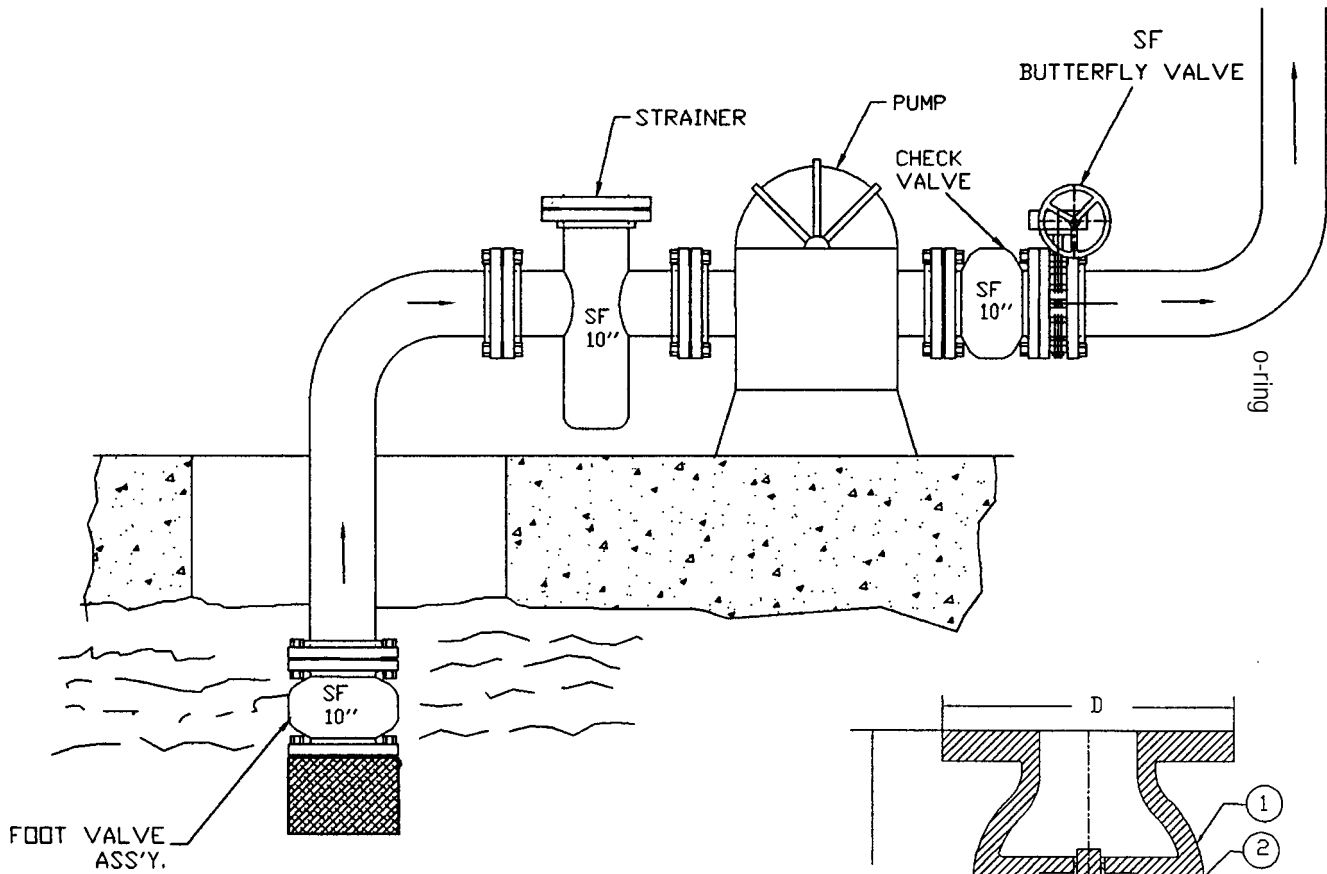

Construction - Cast Steel

No	Name	Material
1	Body Ass'y	CF 125 IS/C
2	Quad Ring	Buna-N o-ring
3	Studs	SA 194 B7 Steel
4	Hex Nuts	SA 194 Steel
5	Slip-on Flng	Flat Face ASTM A105
6	Cap Screw	Stainless Steel
7	Screen	Stainless Steel
8	Gasket Ring	Red Rubber

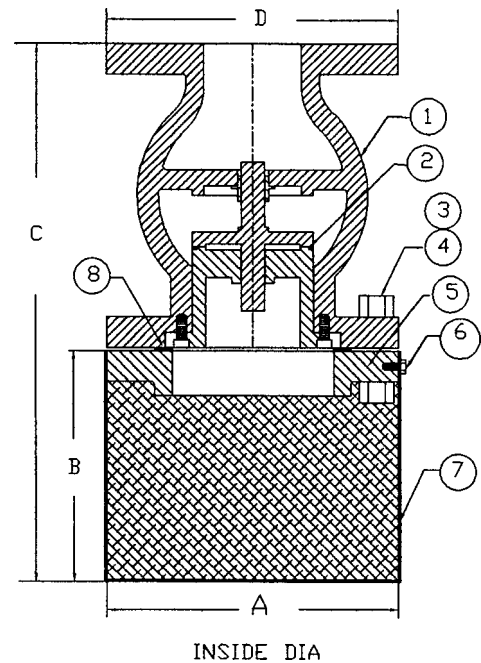

Dimensional Data

Size	A	B	C	D	Shipping Wgt (lbs.)	
Inches Prefix						
2	0200	6	3	9 7/16	6	25
2 1/2	0250	7	3	10 3/16	7	35
3	0300	7 1/2	3	10 11/16	7 1/2	45
4	0400	9	3	11 11/16	9	70
5	0500	10	4	13 11/16	10	90
6	0600	11	5	15 11/16	11	110
8	0800	13 1/2	6	19 11/16	13 1/2	180
10	1000	16	7	23 7/16	16	250
12	1200	19	8	28 7/16	19	400

Notes:

Manufacturer reserves the right to modify dimensions, materials, or design. Contact factory for certification.

Sure Flow Equipment Inc. — LIMITED WARRANTY —

All products are warranted to be free of defects in material and workmanship for a period of one year from the date of shipment, subject to below. **All custom products are not subject to return, credit or refund.**

If the purchaser believes a product to be defective, the purchaser shall:

- (a) Notify the manufacturer, state the alleged defect and request permission to return the product. Merchandise will not be accepted for return without a "Return Code" clearly marked on the outside of the package. Contact the office to obtain a return code.
- (b) If permission is given, return the product with the transportation **prepaid**. Collect shipments will not be accepted. Goods must be returned prepaid.

If the product is accepted for return and found to be defective, the manufacturer will, at its discretion, either repair or replace the product, f.o.b. factory, within 60 days of receipt, or issue credit for the purchase price.

Other than to repair, replace or credit as described above, purchaser agrees that manufacturer shall not be liable for any loss, costs, expenses or damages of any kind arising out of the product, its use, installation or replacement, labeling, instructions, information or technical data of any kind, description of product or use, sample or model, warnings or lack of any of the foregoing.

NO OTHER WARRANTIES, WRITTEN OR ORAL, EXPRESS OR IMPLIED, INCLUDING THE WARRANTIES OF FITNESS FOR A PARTICULAR PURPOSE AND MERCHANTABILITY, ARE MADE OR AUTHORIZED. NO AFFIRMATION OF ACT, PROMISE, DESCRIPTION OF PRODUCT OR USE OR SAMPLE OR MODEL SHALL CREATE ANY WARRANTY FROM MANUFACTURER, UNLESS SIGNED BY THE PRESIDENT OF MANUFACTURER.