

Excellence in Manufacturing
UNAFLEX[®] LLC.
ISO 9001:2008 CERTIFIED



RUBBER Expansion Joints and Flexible Connectors

2011 Revision



WHY UNAFLEX?

...because we are the GOLD STANDARD in the manufacture of expansion joints and hoses!

Expansion joints are critical system components in a vast array of industries. Their purchase and supply should not be trusted to just anyone.

The Unaflex® QUALITY MANAGEMENT SYSTEM is certified to ISO 9001:2008 which insures quality control of the product is rigorous and routinely monitored. Compliance inspections and audits are conducted throughout the year to guarantee continuity and compliance with all ISO requirements.

Our product line includes Rubber Expansion Joints, Metal Bellows Type Expansion Joints, High Temperature Fabric Expansion Joints and PTFE Expansion Joints, as well as Flexible Braided Metal Hose. All are manufactured in our South Carolina facility and we encourage plant tours.

Our state-of-the-art manufacturing facilities provide all of the specialized equipment and tooling necessary to produce the diversified product line Unaflex® offers. We provide FULL TRACEABILITY of our products from raw materials through the finished product.

EXPERIENCED FACTORY SUPPORT is available to all customers who desire a more personal and hands-on approach to ensure the proper selection, production, delivery and installation of our product. PROFESSIONAL ENGINEERING SERVICE is provided by staff highly experienced in the use of finite element analysis software and auto-cad.

Unaflex® employs some of the most knowledgeable sales engineers in the industry who are available for prompt, courteous and exceptional professional service. Our customer service is THE best in the industry.

Distributors and Dealers in partnership with Unaflex® are located throughout the United States of America and are the most reliable and dedicated suppliers available for our specialized product line. Many of our partners stock our full line of products and are able to provide IMMEDIATE service.

FUTURE SUPPORT of our product is how we attract and keep our customers. Unaflex®, a wholly owned family business, has a long and successful track record in the industry. We look forward to many more!

**3901 NE 12th Avenue • Pompano Beach, FL 33064 | On the Web at www.unaflex.com | Email: sales@unaflex.com
CALL TOLL FREE: 1-800-327-1286 • Fax (954) 941-7968**





APPROVE PAGE ORDER BEFORE
CREATING TOC

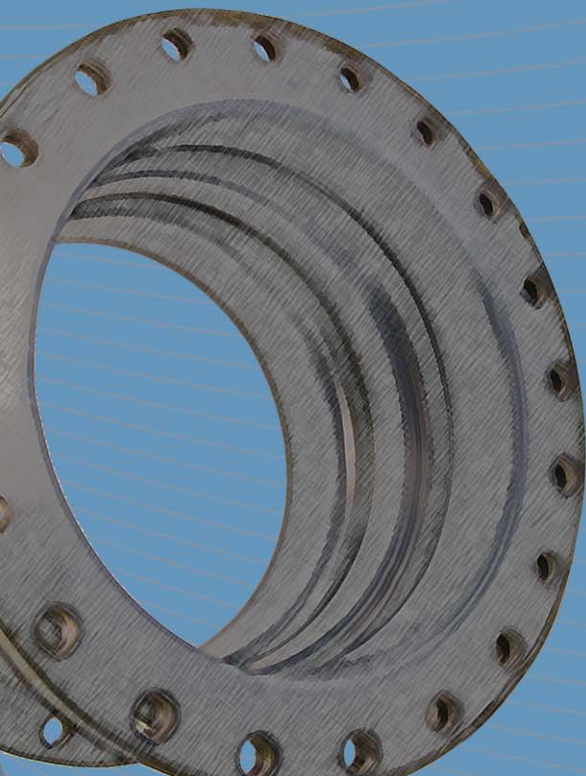

THE ADVANTAGES OF RUBBER EXPANSION JOINTS AND FLEXIBLE CONNECTORS

- Prevents stress due to expansion and contraction
- Insulates against the transfer of noise and vibration
- Compensates for misalignment
- No electrolysis
- Greater recovery from movement
- Freedom from corrosion
- Ease of installation
- Small space requirements



STYLE 150

- **The heavy duty proven “industry work horse”**
- Time-tested performer
- Fabric and steel reinforced
- Constructed for maximum strength and reliability
- Available in multi-arch, taper, offset and special constructions
- For pressure and vacuum



STYLE 1000

- Heavy Duty
- Double arch movements with single wide arch
- Reduced movement forces
- Fabric and steel reinforced
- Suitable for pressures up to 200 PSI and vacuum service
- Available in multi-arch, offset and special constructions



STYLE 189

- Lightweight construction
- Low spring rate forces
- Can be built to handle temperatures up to 350°F
- Less force to move; allows maximum movements
- Available in multi-arch, taper, offset and for high temperature applications



STYLE 1100

- Heavy Duty
- Self-flushing
- Highly resistant to chemical and abrasion
- Available in a wide variety of elastomers
- Suitable for vacuum service to 26” mercury



STYLE 200 (XL)

- Extra-reinforced carcass
- For pressures to 300 PSI
- Available in high temperature constructions suitable for temperatures to 400°F
- Available in multiple arch, taper, offset and special constructions



DURA-PERM

- The excellent chemical resistance of Teflon™ combined with the flexibility of rubber
- Thermal stability
- Anti-stick properties
- Available in multiple arch, taper, offset and special constructions



STYLE 800

- Minimizes water hammer and hydraulic shock
- Less force to move; allows maximum movements
- “All-in-one” design eliminates the need for retaining rings
- Also available in two-arch design twin-sphere) for greater movement capabilities



STYLE 600

- Designed to absorb thermal movements and sound vibrations
- Liners and insulation can allow temperatures to 500°F
- Available in multiple arch, taper, offset and special constructions
- Custom drilled or undrilled



STYLE 1200

- Molded wide-arch design
- Greater motion capability from wider arch
- Less force to compress
- Standard 150 lb. ANSIB 16.1 flange drilling
- Standard face-to-face dimensions
- Vacuum 26” HG

WHY USE RUBBER EXPANSION OR VIBRATION JOINTS?

THREE BASIC REASONS FOR THEIR USE:



- 1 TO PREVENT STRESSES DUE TO EXPANSION AND CONTRACTION
- 2 TO INSULATE AGAINST THE TRANSFER OF NOISE AND VIBRATION
- 3 TO COMPENSATE FOR MISALIGNMENT

Unaflex® Rubber Expansion Joints provide relief from stresses caused by thermal expansion and contraction in pipelines. Movement is always experienced in piping systems due to varying ambient temperatures, differences in temperature of materials handled, and differences in composition. Expansion joints absorb this movement and eliminate the danger of buckling or pulling apart with the high replacement costs that would result.

Pumps, compressors and other pulsating equipment generate noise and vibration. The transmission of noise and vibration tends to reduce the efficiency of adjacent equipment and impairs working conditions in offices and plants. Expansion joints serve as reliable insulation against such vibration and noise. Settlement, load stresses and normal wear of components will frequently cause piping and mechanical equipment to become misaligned. Expansion joints can resolve these problems within their design limits. Special designed expansion joints are available for specific conditions and misalignment.

DEFINITION OF MOVEMENT

Axial Compression

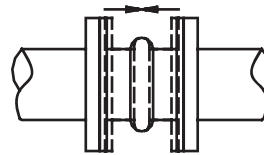

Reduction of face-to-face dimension measured along the axis.

Axial Elongation

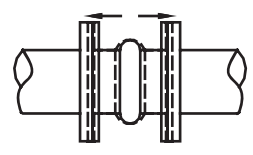

Increase of face-to-face dimension measured along the axis.

Transverse or Lateral Movement

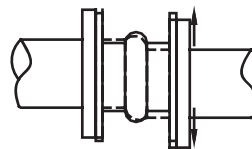

The movement of the joint perpendicular to the axis.

Vibration Absorption

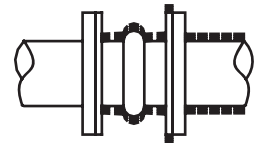

The movement of the joint due to vibrations which are effectively intercepted and insulated against transmission to remainder of system.

Angular Movement

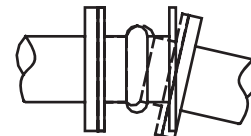

The displacement of the longitudinal axis of the joint from its initial straight line position (a combination of axial elongation and axial compression).

CONTROL UNITS

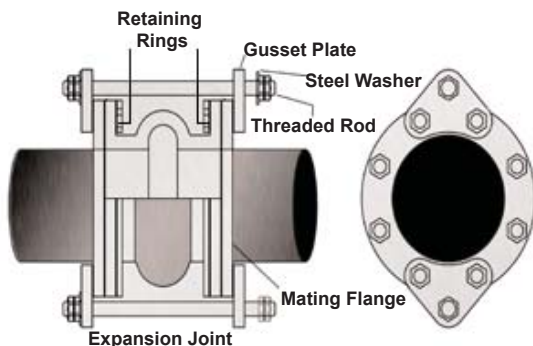

Excessive elongation, caused by shifting of pipelines may seriously damage rubber expansion joints. This damage can occur when necessary support is not provided for the weight of the pipeline or low temperatures in the line are encountered, or when the system on the pressure side of air compressors are not anchored properly.

Such destructive elongation can be controlled with Unaflex® control units. These units are recommended for use where such conditions occur, such as on air-conditioning units that are subjected to reduced temperatures.

ADVANTAGES OVER METAL EXPANSION JOINTS

- Vibration and sound insulation
- Greater recovery from movement
- Freedom from embrittlement
- Resistance to corrosion
- No gaskets between flanges
- No electrolysis
- Axial and lateral deflection
- Small space requirements
- Lightweight
- Ease of installation
- Higher working pressures

TYPICAL RUBBER EXPANSION JOINT APPLICATIONS

INDUSTRIAL APPLICATIONS

Piping installations are one of the most important locations for Unaflex® Expansion Joints as they compensate for the thermal expansion and contraction in the line, as well as reduce the transmission of noise and vibration.

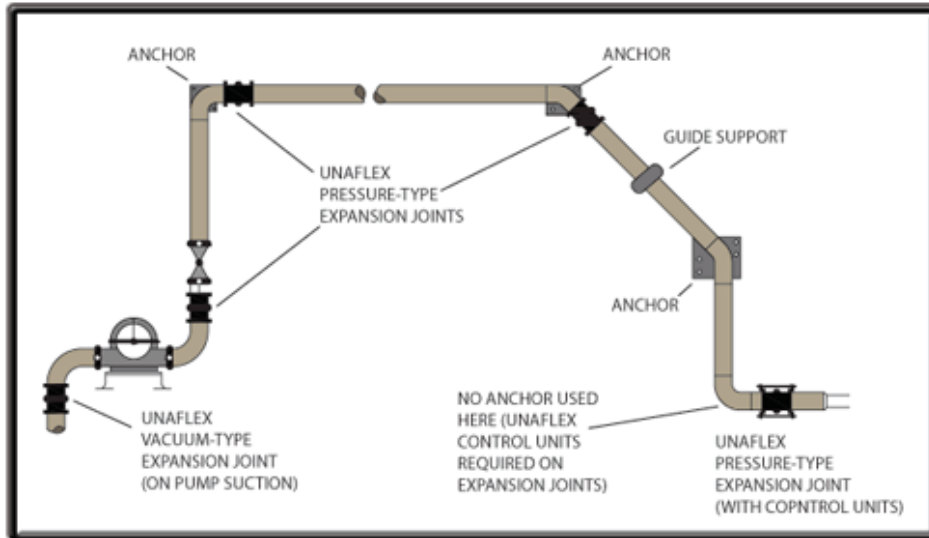

HEATING/AIR CONDITIONING AND VENTILATING

Unaflex® Expansion Joints are used on the header connections to the condenser and to the cooler, as well as in the water circulating lines on both hot and chilled water lines.

They will relieve stresses caused by changes in temperature as well as eliminate the transmission of noise and vibration.

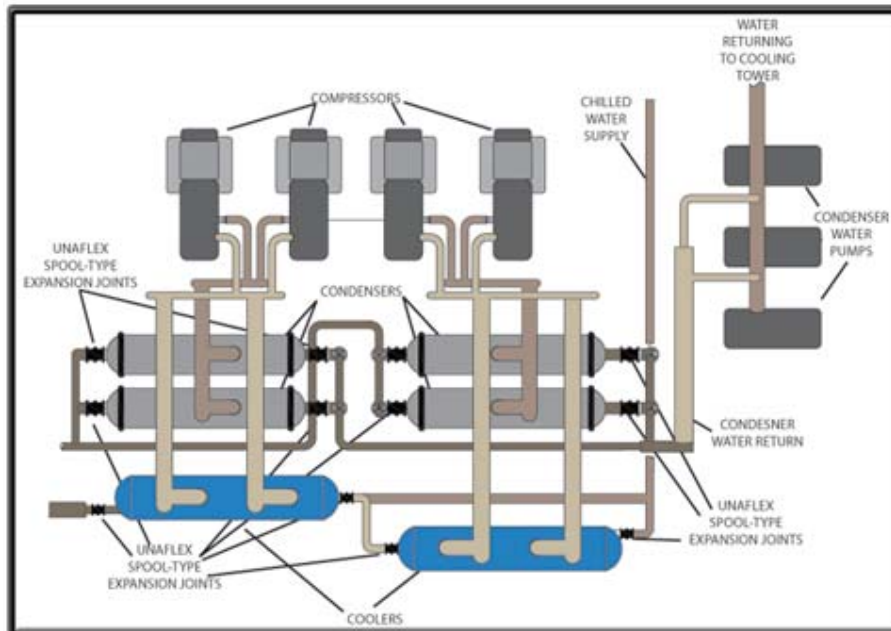

TYPICAL RUBBER EXPANSION JOINT APPLICATIONS

MARINE APPLICATIONS

Unaflex® Expansion Joints eliminate destructive electrolytic action, as well as insulate the transmission of noise and vibration. They are approved by U.S. Navy and U.S. Coast Guard and conform to ABS requirements. Special fire retardant expansion joints conforming to MIL E-15330D are also available.

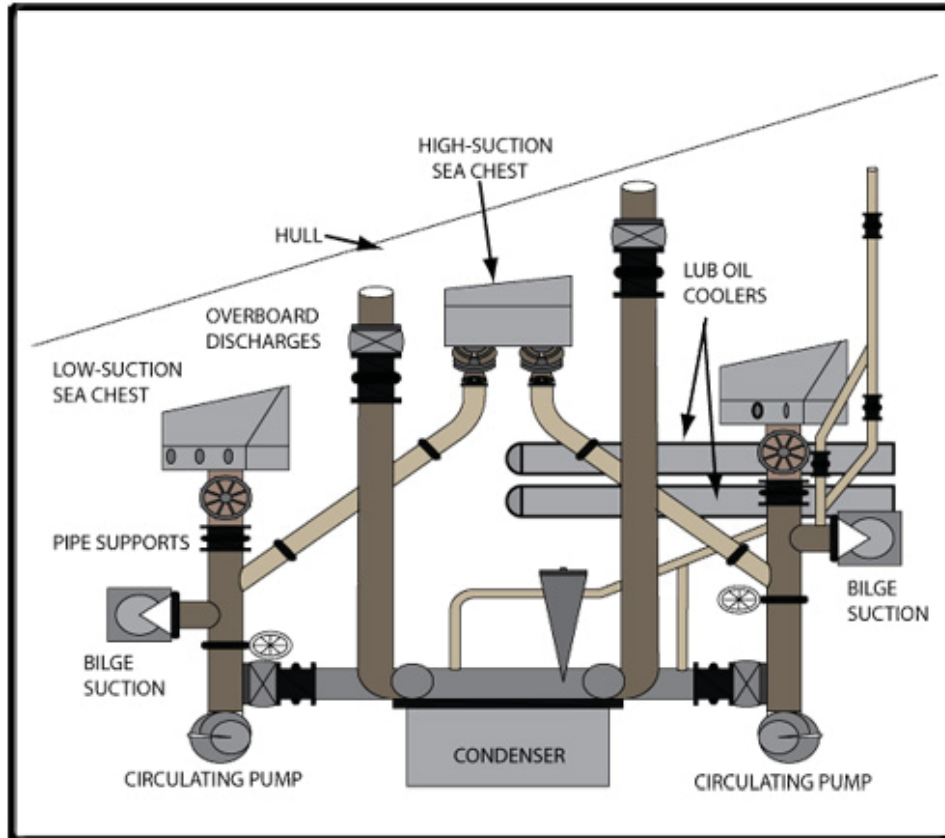

CENTRAL POWER STATIONS

Due to their compactness and ease with which they accommodate all types of movement, Unaflex® Expansion Joints are adaptable to a variety of uses in central power plants. Applications include condenser auxiliary exhaust lines, connections to air ejector, condensate pump, and low-pressure feed suction lines. Special joints available for temperatures up to 350°F and 400°F in flue duct applications.

SEWAGE TREATMENT PLANTS

Unaflex® Rubber Expansion Joints are used on the aeration lines, grit pump line, raw sewage lines and sludge pumps.

VARIATIONS OF CONSTRUCTION

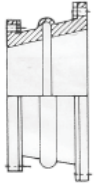

Tapered Joints

Used to connect pipelines of unequal diameter. May be manufactured as concentric or eccentric, depending upon pipe alignment.

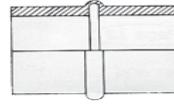

Sleeve-Type Joints

Constructed as a standard spool-type joint minus the integral flanges. I.D. of the sleeve end is the same as the O.D. of the pipe.

Offset Joints

Used to correct initial pipe misalignment greater than 1/8-inch. Drawings must accompany orders or inquiries.

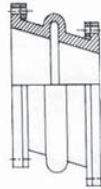

Filled Arches

Built as an integral part of the carcass. They reduce turbulence and prevent the collection of sediment in the arch. Movement of the joint is reduced approximately 50%.

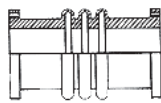
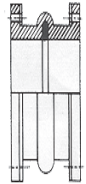

Multiple Arches

Additional arches increase movement of the joint. Movement can be calculated by multiplying the movement of a single arch joint by the number of additional arches.

CONSTRUCTION DETAILS

Flanges

Full-faced and made as an integral part of the joint to insure a tight reliable seal. No gaskets are necessary. Drilled to conform to the bolt pattern of the mating pipe flange.

Tube

A single piece of leakproof lining extending flange-to-flange. Can be furnished in natural rubber, neoprene, chlorobutyl, hypalon, Viton®, nitrile, or other compounds and can also be lined with TEFLON®. All rubber is specially formulated to provide maximum sound and heat insulation as well as abrasion resistance.

Carcass

Strong, bias-ply construction, high-strength woven polyester reinforcing fabric between the tube and cover. Will not rot or mildew and is thoroughly impregnated with a special friction compound to give maximum adhesion under pressure, vacuum and stress.

Steel Reinforcements

Chemically treated, solid-round, endless steel rings or wire embedded in the carcass (with the Unaflex® proprietary method to prevent ring migration) giving maximum strength to the joint. Round rings are used so there will be no sharp edges to cut into the carcass while flexing of the joint occurs, eliminating premature wear.

Steel Retaining Rings

Made of flat-rolled steel, split, beveled and galvanized, painted, fluoropolymer coated or electroplated. Rings are required for installation of the joint.

Cover

The exterior surface of the joint, compounded of fire-retardant neoprene to withstand aging, cracking and corrosion. Other compounds may also be used.

Arch

Arches are built-in as an integral part of the carcass. They function to provide flexibility to the joint in use.

Hand Wrapped Finish

Hand wrapping the finish (although more time consuming in manufacture) insures individual attention so that maximum pressure for curing has been established.

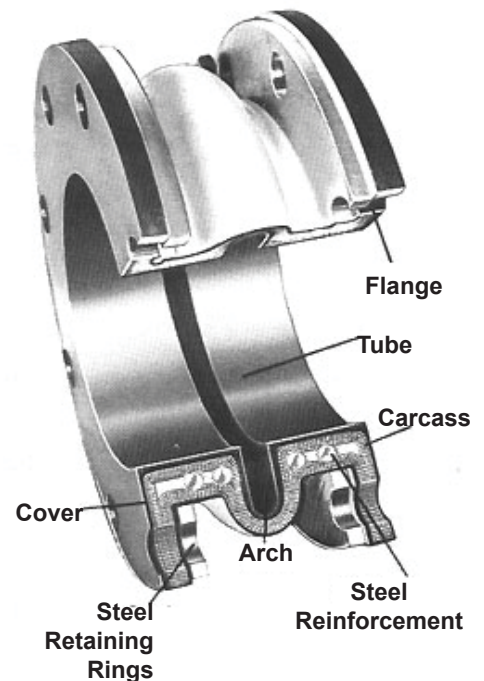

SUGGESTIONS FOR INSTALLATION AND MAINTENANCE

Clean all foreign matter and remove burrs or sharp edges from flanges.

All pipe lines should be properly supported so that the expansion joints do not carry the pipe load.

Remove burrs or sharp edges from flanges.

Do not install joints on raised face flanges of more than 1/16".

All pipes are to be lined up accurately before installing expansion joints. Offset joints should be installed where misalignment is greater than the lateral movement allowed by joint construction.

Paint flange face with a mixture of ordinary graphite mixed with enough glycerine to form a thin paste. This will assist removal if it should become necessary.

Bolts should be on the inside of the joint flange. Metal washer must be placed at the facing of the split retaining rings.

Bolts should be tightened by alternating around the flange and all tightened equally.

Slight gouges or abraded areas caused by tools or bolts during installation should be sealed with rubber cement and painted to prevent deterioration of the carcass.

Bolt tightness should be checked one week after going on stream and checked periodically thereafter.

Joints installed outdoors should have a neoprene cover. All joints should be painted with Unaflex® Hypalon paint.

All joints should be painted with Unaflex® Hypalon paint once a year.

If system is not anchored to ensure against movement beyond maximum stated limits, control units must be used.

“SUPREME” SPOOL-TYPE EXPANSION JOINTS

Unaflex® “SUPREME” Spool-Type Expansion Joints are available in three basic styles:

- Style 150 for pressure and vacuum
- Style 1000 for pressure, vacuum and greater movement
- Style 200 for high-pressure service. Joints that handle up to 500°F are available.
- Style 200XL for extra high pressure service (consult factory)

These basic types can be manufactured to meet the requirements of ASTM F1123-87 (Note: The U.S. Navy previously used MIL-E-15330D, Class A-Type I as its standard specification, but has adopted the ASTM Specification).

Unaflex® Expansion Joints can be made with filled arch, multiple arches, TEFLON®; PTFE and (FEP)-lined, sleeve ends, without arch, tapered (eccentric or concentric), with enlarged arch and with special tube compounds for air, gas, oil, petroleum products, acids and chemicals of many types.



UNAFLEX® “SUPREME” TAPERED EXPANSION JOINTS

Unaflex® “SUPREME” Tapered Spool-Type Expansion Joints are available in four types; Style 150, 1000, 200 and 200XL. Tapered joints are used to connect flanges with different diameters, whether parallel or offset, with initial misalignment less than 1/8-inch.

Tapered joints can be made with the following variations: with filled arch, sleeve ends, without arch; with special tube materials; with larger arch; with straight section on smaller end of joint to assure clearance of bolts on eccentric type joints and on joints with considerable taper.

Both concentric and eccentric shapes are available in a wide variety of sizes. As with the regular expansion joints, when piping is not anchored, control units must be used to prevent over-elongation of the joints.

For determining operating characteristics, use the largest I.D. dimension of the tapered expansion joint for specifying.

Note: Unaflex® Flexible Rubber Pipe can also be supplied in the tapered construction.

ECCENTRIC CONCENTRIC

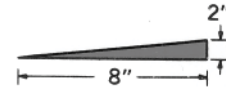
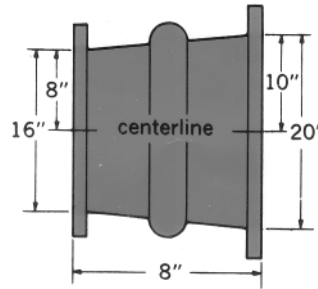
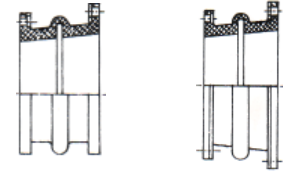

Example:
20" ID x 16" ID x 8" F-F
 $\text{Arctan}(2/8) = \text{Arctan}(0.25) = 14 \text{ degrees}$
Note: drawing not to scale

Engineering Data for Tapered Expansion Joints

The degree of taper should not exceed 25°. Where a taper is more than 15° a filled arch is recommended. Where a filled arch is utilized, the available movement will be decreased 50% from that of an open arch. Where a proposed taper is greater than 25°, we recommend a steel reducer be utilized and a spool-type expansion joint be used in the adjacent piping.

The above guides are generally applicable to concentric tapers. Where an eccentric taper exceeds 25°, consult Unaflex® engineering department.

ORDERING INFORMATION FOR STYLES 150, 200 & 1000

Temperature Limits for Continuous Service			
Style	Temp	Style	Temp
150	180°	150 HTS	300°
200	180°	200 HTS	300°
1000	180°	1000 HTS	300°
1100	180°	150 V	400°
150 HT	250°	200 V	400°
200 HT	250°	1000 V	400°
1000 HT	250°	189 SG	400°
1100 HT	250°		

To receive a quotation or when placing an order, please specify the following:

- Style (140, 150, etc.)
- Quantity
- Inner Diameter
- Flange Drilling
- Materials Conveyed in Line
- Pressure and/or Vacuum Ranges
- Temperature Range
- Movements-Axial Compression, Extension and Lateral Deflection

Specify Unaflex® “SUPREME” Rubber Expansion Joints as follows:

- Style 150 for pressure and vacuum service
- Style 1000 for pressure and vacuum with greater movement
- Style 200 for high pressure service

Minimum Face-to-Face Dimensions For Styles 150, 200 & 1000			
Joint Size I.D. (in.)	Single Arch Min. f-f (in.)	Double Arch Min. f-f (in.)	Triple Arch Min. f-f (in.)
1/2 to 6	6	10/12*	12/16*
8	6	10/12*	14/18*
10	8	12/16*	14/20*
12	8	12/16*	14/20*
14 to 20	8	12/16*	16/20*
22 to 24	10	14/16*	18/22*
26 to 34	10	14/16*	18/22*
36 to 40	10	14/18*	18/22*
42 to 96	12	14/18*	18/22*
*Wide Arch Style 1000			
Note: These face-to-face dimensions are only a guide. Consult factory for special requirements.			

Contact our Engineering Department for Complete Data and Specifications

Call Toll Free: (800) 327-1286, Fax: (954) 941-7968 or visit www.unaflex.com or email: sales@unaflex.com

Style 150—For pressure/vacuum service

Style 189—For high temp and low spring rate, pressure limited to 25 psi

Style 200—For heavy duty high pressure/vacuum service

Style 200XL—For very high pressures. Consult factory for construction details

Style 1000—Wide arch offers more movement. Hand wrapped build process offers a large variety of construction variations.

Style 1100—Wide arch offers more movement. Molded design keeps cost low.

“SUPREME” LIGHTWEIGHT AND U-TYPE EXPANSION JOINTS

UNAFLEX STYLE 189 DIMENSIONS & SPECIFICATIONS

Arch	Joint Size I.D. (in.)	Min. Face-to-Face (in.)	Comp. (in.)	Ext. (in.)	Lateral (in.)
Single	2 to 5	8	7/16	5/16	5/8
	6 to 13	8	11/16	9/16	5/8
	14 to 24	8	13/16	11/16	5/8
	25 to 30	8	15/16	13/16	5/8
Double	2 to 5	12	7/8	5/8	1-1/4
	6 to 13	12	1-3/8	1-1/8	1-1/4
	14 to 24	13	1-5/8	1-3/8	1-1/4
	25 to 30	13	1-7/8	1-5/8	1-1/4
Triple	2 to 5	16	1-5/16	15/16	2-1/2
	6 to 13	16	2-1/16	1-11/16	2-1/2
	14 to 24	18	2-7/16	2-1/16	2-1/2
	25 to 30	18	2-13/16	2-7/16	2-1/2

Maximum operating pressures for all sizes is 25 psig internal pressure and 15 inches of mercury vacuum

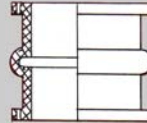
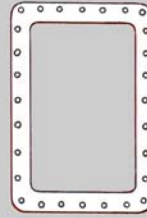

Unaflex® “SUPREME” Style 189 Lightweight Rubber Expansion

Joints are available in either round or rectangular (with arch) configurations. They are recommended for pressure and limited vacuum applications such as: air, gas and water service where pressures are low and medium-not too severe. They may also be used on equipment where temperatures do not exceed 180°F.



They feature a lighter wall and flange thickness to provide flexibility. Their duck plies are reinforced with steel rings. Style 189 Joints are also available for temperatures up to 500°F and can be made with sleeve ends.

UNAFLEX STYLE 145, 155, 156, 157 AND 185

Unaflex® “SUPREME” U-Style Rubber Expansion Joints form a flexible connection between equipment outlet and inlet flanges. They are normally constructed of a natural rubber tube, several heavy plies of rubber or neoprene-impregnated fabric and a neoprene cover to protect the carcass. Consult engineering department for maximum operating temperature. They are available in the following configurations.

RECTANGULAR (STYLE 145)

With internal flange (no arch) for vacuum and pressure. They allow ample axial and lateral movement capable of withstanding 30-inches of vacuum, or 25psi gauge internal pressure. Retaining flanges are provided for support.

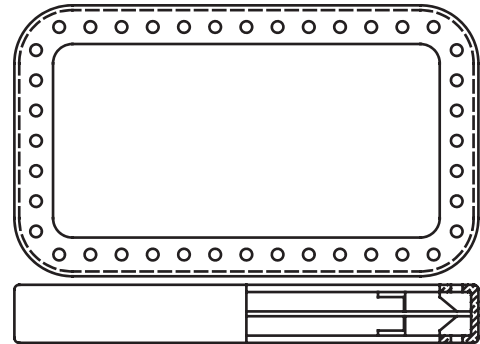

OVAL (STYLE 155 & 157)

With external flange. Available in Style 155 for vacuum only and Style 157 for pressure and vacuum. Used in installations where external bolting is desired. Style 155 withstands 30 inches of vacuum with standard flat steel retaining rings. Style 157 is designed for both 30 inches of vacuum and 25psi gauge internal pressure and are designed with special steel fabricated support rings.

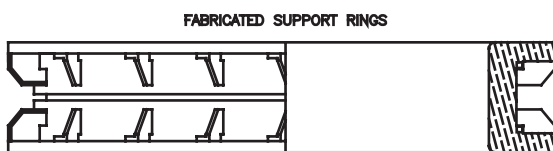
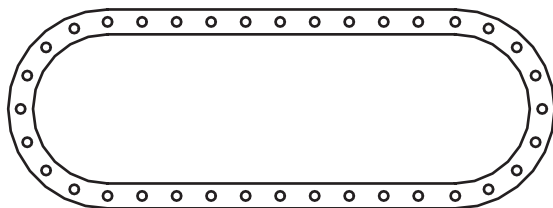

FABRICATED SUPPORT RINGS

ROUND (STYLE 156 & 185)

Lightweight rubber expansion joints available in Style 156, “U”-Type, no arch, for vacuum only; Style 185, round “U”-Type, no arch, steel reinforced for vacuum and pressure. Style 156 body is of duck and rubber without metal reinforcing. Style 185 is constructed with steel reinforcement. These units can also be supplied with offset features.

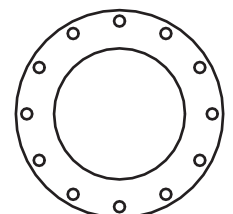

DIMENSIONS FOR “SUPER FLEX WIDE ARCH & SUPREME ” SPOOL-TYPE (SINGLE ARCH) EXPANSION JOINTS

(Measurement in inches)			Bolt Holes		Bolt Hole Dia.	Ret. Ring I.D.	Flange Thk.	NOTE: All joints suitable for vacuum service and can be manuf. for full vac.					Axial Extension		Traverse Deflection		Estimated Weights				
Joint Size N.D.	Face-to-Face	Flange O.D.	Bolt Circle Dia.	No. of Bolts				Maximum Working Pressure			Axial Compression		Allow. Mvt. 150/200	Allow. Mvt. 1000	Allow. Mvt. 150/200	Allow. Mvt. 1000	Allow. Mvt. 150/200	Allow. Mvt. 1000	Exp. Joint	Ret. Rings	Cntrl. Units
								Style 150	Style 200	Style 1000	Allow. Mvt. 150/200	Allow. Mvt. 1000									
1/2	6	3-1/2	2-3/8	4	9/16	1-5/8	1/2	165	200	165	7/16	1.75	1/4	.75	1/2	.75	1	1.5	6		
3/4	6	3-7/8	2-3/4	4	9/16	1-7/8	1/2	165	200	165	7/16	1.75	1/4	.75	1/2	.75	1.5	2	6		
1	6	4-1/4	3-1/8	4	5/8	2-3/8	9/16	165	200	165	7/16	1.75	1/4	.75	1/2	.75	2	2	6		
1-1/4	6	4-5/8	3-1/2	4	5/8	2-5/8	9/16	165	200	165	7/16	1.75	1/4	.75	1/2	.75	2.5	2.5	6		
1-1/2	6	5	3-7/8	4	5/8	2-7/8	9/16	165	200	165	7/16	1.75	1/4	.75	1/2	.75	3	3	6		
2	6	6	4-3/4	4	3/4	3-5/8	9/16	165	200	225	7/16	1.75	1/4	.75	1/2	.75	4	4	6		
2-1/2	6	7	5-1/2	4	3/4	4-1/8	9/16	165	200	225	7/16	1.75	1/4	.75	1/2	.75	4.5	5.5	7		
3	6	7-1/2	6	4	3/4	4-5/8	9/16	165	200	225	7/16	1.75	1/4	.75	1/2	.75	5.5	6	8		
4	6	9	7-1/2	8	3/4	5-7/8	9/16	165	200	225	7/16	1.75	1/4	.75	1/2	.75	8	7.5	7		
5	6	10	8-1/2	8	7/8	6-7/8	9/16	165	200	225	7/16	1.75	1/4	.75	1/2	.75	9	8	7		
6	6	11	9-1/2	8	7/8	7-7/8	5/8	140	200	225	7/16	1.75	1/4	.75	1/2	1.00	11	9	9		
8	6	13-1/2	11-3/4	8	7/8	9-7/8	3/4	140	200	225	7/16	1.75	1/4	.75	1/2	1.00	15	12	12		
10	8	16	14-1/4	12	1	12-1/8	3/4	140	190	225	7/16	1.75	1/4	.75	1/2	1.00	23	16	16		
12	8	19	17	12	1	14-1/2	3/4	140	190	225	11/16	1.75	3/8	.75	1/2	1.00	34	22	16		
14	8	21	13-3/4	12	1-1/8	16-1/2	7/8	140	190	225	11/16	1.75	3/8	.75	1/2	1.00	40	25	20		
16	8	23-1/2	21-1/4	16	1-1/8	18-1/2	7/8	85	130	160	11/16	1.75	3/8	.75	1/2	1.00	47	27	20		
18	8	25	22-3/4	16	1-1/4	20-1/2	7/8	65	110	160	11/16	1.75	3/8	.75	1/2	1.00	56	29	21		
20	8	27-1/2	25	20	1-1/4	22-5/8	1	65	110	130	11/16	1.75	3/8	.75	1/2	1.00	67	35	21		
22	10	29-1/2	27-1/4	20	1-3/8	24-5/8	1	65	110	130	13/16	1.75	7/16	.75	1/2	1.00	70	44	32		
24	10	29-1/2	29-1/2	20	1-3/8	26-5/8	1	65	100	130	13/16	1.75	7/16	1.00	1/2	1.00	79	46	32		
26	10	32	31-3/4	24	1-3/8	28-7/8	1	65	100	110	15/16	1.75	1/2	1.00	1/2	1.00	100	50	32		
28	10	34-1/4	34	28	1-3/8	30-7/8	1	55	90	110	15/16	1.75	1/2	1.00	1/2	1.00	102	55	32		
30	10	36-1/2	36	28	1-3/8	32-7/8	1	55	90	95	15/16	2.25	1/2	1.00	1/2	1.00	117	58	32		
34	10	38-3/4	40-1/2	32	1-5/8	37	1	55	90	95	15/16	2.25	1/2	1.25	1/2	1.00	122	91	43		
36	10	43-3/4	42-3/4	32	1-5/8	39	1	55	90	95	15/16	2.25	1/2	1.25	1/2	1.00	143	99	43		
40	10	46	47-1/4	36	1-3/4	43	1	55	90	90	15/16	2.25	1/2	1.25	1/2	1.00	173	108	43		
42	12	50-3/4	49-1/2	36	1-5/8	45-1/4	1-3/16	55	90	90	15/16	2.25	1/2	1.25	1/2	1.00	193	110	44		
44	12	53	51-3/4	40	1-3/4	47-1/4	1-3/16	55	80	90	15/16	2.25	1/2	1.25	1/2	1.00	198	136	44		
48	12	55-1/4	56	44	1-5/8	51-1/4	1-3/16	55	80	90	15/16	2.25	1/2	1.25	1/2	1.00	211	154	87		
50	12	59-1/2	58-1/4	44	1-7/8	53-1/4	1-3/16	55	80	85	15/16	2.25	1/2	1.25	1/2	1.00	240	163	87		
54	12	61-3/4	62-3/4	44	2	57-1/4	1-3/16	55	80	85	15/16	2.25	1/2	1.25	1/2	1.00	265	185	87		
56	12	66-1/4	65	48	2	59-1/4	1-3/16	55	80	85	15/16	2.25	1/2	1.25	1/2	1.00	288	203	87		
60	12	68-3/4	69-1/4	52	2	63-1/4	1-3/16	55	80	85	15/16	2.25	1/2	1.25	1/2	1.00	309	215	87		
62	12	73	71-3/4	52	2	65-1/4	1-3/16	55	80	85	15/16	2.25	1/2	1.25	1/2	1.00	325	230	87		
66	12	75-3/4	76	52	2	69-1/4	1-3/16	55	80	85	15/16	2.25	1/2	1.25	1/2	1.00	350	255	87		
72	12	80	82-1/2	60	2	75-1/4	1-3/16	45	70	85	15/16	2.25	1/2	1.25	1/2	1.00	385	300	87		
78	12	86-1/2	88-3/4	64	2-1/8	81-1/4	1-3/16	45	70	80	15/16	2.25	1/2	1.25	1/2	1.00	410	325	103		
84	12	99-3/4	95-1/2	64	2-1/4	87-1/2	1-3/16	45	70	80	1	2.25	9/16	1.25	1/2	1.00	435	350	113		
96	12	113-1/4	108-1/2	68	2-1/2	99-3/8	1-3/16	45	70	80	1	2.25	9/16	1.25	1/2	1.00	460	375	125		

Technical statements and engineering data in this catalog is the most accurate information available at the time of printing and are subject to change without notice. As Unaflex® does not supervise or control the use of our products, Unaflex® cannot be responsible for improper use or misapplication of catalog data.

Note:

- All charts are applicable to DURA-PERM TEFLON® Expansion Joints with respect to Temperature and Pressure data.
- For a filled arch, reduce available movements by 50%.
- For multiple arch expansion joints, take the movement shown above and multiply by the number of arches.

Contact our Engineering Department for complete data and specifications.

Call Toll Free:1 (800) 327-1286

Table 1: Optional Flange Drillings (other flange drillings available, consult factory)

American 250/300# Conforms to ANSI B16.1 and B16.5						British Standard 10:1962 Conforms to B.S-10 Table E					Metric Series 1 Conforms to I.S.O. 2084-1974 Table NP-10					J.I.S. Standard B-2212 Conforms to J.I.S. 10KG/CM				
I.D. in-mm	Flange Width	Flange O.D.	Bolt Circle	No. of Holes	Hole Dia.	Flange Width	Flange O.D.	Bolt Circle	No. of Holes	Hole Dia.	Flange Width	Flange O.D.	Bolt Circle	No. of Holes	Hole Dia.	Flange Width	Flange O.D.	Bolt Circle	No. of Holes	Hole Dia.
1 25	.59 15.0	4.88 124.0	3.5 89.0	4 4	.75 19.0	.59 15.0	4.5 114.3	3.25 82.6	4 4	.75 19.0	.59 15.0	4.53 115.0	3.35 85.0	4 4	.55 14.0	.59 15.0	4.92 125.0	3.54 90.0	4 4	.75 19.0
1-1/4 32	.59 15.0	5.25 133.0	3.88 98.0	4 4	.75 19.0	.59 15.0	4.75 120.7	3.44 87.3	4 4	.75 19.0	.59 15.0	5.51 140.0	3.94 100.0	4 4	.71 18.0	.59 15.0	5.31 135.0	3.94 100.0	4 4	.75 19.0
1-1/2 40	.59 15.0	6.12 156.0	4.5 114.0	4 4	.88 22.2	.59 15.0	5.25 133.4	3.88 98.4	4 4	.88 22.2	.59 15.0	5.91 150.0	4.33 110.0	4 4	.71 18.0	.59 15.0	5.51 140.0	4.13 105.0	4 4	.75 19.0
2 50	.71 18.0	6.5 165.0	5.0 127.0	8 8	.75 19.0	.63 16.0	6.0 152.4	4.5 114.3	8 8	.75 19.0	.71 18.0	6.5 165.0	4.92 125.0	4 4	.71 18.0	.63 16.0	6.1 155.0	4.72 120.0	4 4	.75 19.0
2-1/2 65	.71 18.0	7.5 191.0	5.88 149.0	8 8	.88 22.2	.71 18.0	6.5 165.1	5.0 127.0	8 8	.88 22.2	.71 18.0	7.28 185.0	5.71 145.0	4 4	.71 18.0	.71 18.0	6.89 175.0	5.51 140.0	4 4	.75 19.0
3 80	.79 20.0	8.25 210.0	6.62 168.0	8 8	.88 22.2	.71 18.0	7.25 184.2	5.75 146.1	8 8	.88 22.2	.79 20.0	7.87 200.0	6.3 160.0	8 8	.71 18.0	.71 18.0	7.28 185.0	5.91 150.0	8 8	.75 19.0
3-1/2 90	.79 20.0	9.0 229.0	7.25 184.0	8 8	.88 22.2	.71 18.0	8.0 203.2	6.5 165.1	8 8	.88 22.2	.79 20.0	- -	- -	- -	- -	.71 18.0	7.68 195.0	6.3 160.0	8 8	.75 19.0
4 100	.79 20.0	10.0 254.0	7.88 200.0	8 8	.88 22.2	.71 18.0	8.5 215.9	7.0 177.8	8 8	.88 22.2	.79 20.0	8.66 220.0	7.09 180.0	8 8	.71 18.0	.71 18.0	8.27 210.0	6.89 175.0	8 8	.75 19.0
5 125	.87 22.0	11.0 279.0	9.25 235.0	8 8	.88 22.2	.79 20.0	10.0 254.0	8.25 209.6	8 8	.88 22.2	.87 22.0	9.84 250.0	8.27 210.0	8 8	.71 18.0	.79 20.0	9.84 250.0	8.27 210.0	8 8	.91 23.0
6 150	.87 22.0	12.5 318.0	10.62 270.0	12 12	.88 22.2	.87 22.0	11.0 279.4	9.25 235.0	12 12	.88 22.2	.87 22.0	11.22 285.0	9.45 240.0	8 8	.87 22.0	.87 22.0	11.02 280.0	9.45 240.0	8 8	.91 23.0
8 200	.94 24.0	15.0 381.0	13.0 330.0	12 12	1.0 25.4	.87 22.0	13.25 336.6	11.5 292.1	12 12	1.0 25.4	.94 24.0	13.39 340.0	11.61 295.0	8 8	.87 22.0	.87 22.0	12.99 330.0	11.42 290.0	12 12	.91 23.0
10 250	1.02 26.0	17.5 445.0	15.25 387.0	16 16	1.12 28.6	.94 24.0	16.0 406.4	14.0 355.6	16 16	1.12 28.6	1.02 26.0	15.55 395.0	13.79 350.0	12 12	.87 22.0	.94 24.0	15.75 400.0	13.98 355.0	12 12	.98 25.0
12 300	1.02 26.0	20.5 521.0	17.75 451.0	16 16	1.25 31.8	.94 24.0	18.0 457.2	16.0 406.4	16 16	1.25 31.8	1.02 26.0	17.52 445.0	15.75 400.0	12 12	.87 22.0	.94 24.0	17.52 445.0	15.75 400.0	16 16	.98 25.0
14 350	1.10 28.0	23.0 584.0	20.25 514.0	20 20	1.25 31.8	1.02 26.0	20.75 527.1	18.5 469.9	20 20	1.25 31.8	1.10 28.0	19.88 505.0	18.11 460.0	16 16	.87 22.0	1.02 26.0	19.29 490.0	17.52 445.0	16 16	.98 25.0
16 400	1.26 32.0	25.5 648.0	22.5 572.0	20 20	1.38 34.9	1.1 28.0	22.75 577.9	20.5 520.7	20 20	1.38 34.9	1.26 32.0	22.24 656.0	20.28 515.0	16 16	1.02 26.0	1.1 28.0	22.05 560.0	20.08 510.0	16 16	1.06 27.0
18 450	1.42 36.0	28.0 711.0	24.75 629.0	24 24	1.38 34.9	1.18 30.0	25.25 641.4	23.0 584.2	24 24	1.38 34.9	1.42 36.0	24.21 615.0	22.24 565.0	20 20	1.02 26.0	1.18 30.0	24.41 620.0	22.24 565.0	20 20	1.06 27.0
20 500	1.50 38.0	30.5 775.0	27.0 686.0	24 24	1.38 34.9	1.18 30.0	27.75 704.9	25.25 641.4	24 24	1.38 34.9	1.50 38.0	26.38 670.0	24.41 620.0	20 20	1.02 26.0	1.18 30.0	26.57 675.0	24.41 620.0	20 20	1.06 27.0
22 550	1.50 38.0	33.0 838.0	29.25 743.0	24 24	1.38 34.9	1.18 30.0	30.0 762.0	27.5 698.5	24 24	1.38 34.9	1.50 38.0	28.74 730.0	26.57 675.0	20 20	1.18 30.0	1.18 30.0	29.33 745.0	26.77 680.0	20 20	1.3 33.0
24 600	1.50 38.0	36.0 914.0	32.0 813.0	24 24	1.62 41.3	1.18 30.0	32.5 825.5	29.75 755.7	24 24	1.62 41.3	1.50 38.0	30.71 780.0	28.54 725.0	20 20	1.18 30.0	1.18 30.0	31.3 795.0	28.74 730.0	24 24	1.3 33.0
26 650	1.50 38.0	38.25 972.0	34.5 876.0	28 28	1.75 44.5	1.18 30.0	- -	- -	28 28	1.75 44.5	1.50 38.0	32.87 835.0	30.71 780.0	24 24	1.18 30.0	- -	- -	- -	- -	- -
28 700	1.50 38.0	40.75 1035.0	37.0 940.0	28 28	1.75 44.5	1.18 30.0	- -	- -	28 28	1.75 44.5	1.50 38.0	35.24 895.0	33.07 840.0	24 24	1.18 30.0	- -	- -	- -	- -	- -
30 750	1.50 38.0	43.0 1092.0	39.25 997.0	28 28	2.0 50.8	1.18 30.0	39.25 997.0	36.5 927.1	28 28	2.0 50.8	1.50 38.0	37.99 965.0	35.43 900.0	24 24	1.3 33.0	- -	- -	- -	- -	- -

Table 2: Standard/Special Drilling • Expansion Joint Dimensions • Control Units

125/150# Flange Dimensions Joints/Rings/Rods					250/300# Flange Dimensions Joints/Rings/Rods					Weights of Retaining Rings		125/150# Flange Dimensions Joints/Rings/Rods					250/300# Flange Dimensions Joints/Rings/Rods					Weights of Retaining Rings	
Joint I.D.	Flange O.D.	Bolt Circle	No. of Holes	Hole Size	Flange O.D.	Bolt Circle	No. of Holes	Hole Dia.	150# Rings Wt./#	300# Rings Wt./#	Joint I.D.	Flange O.D.	Bolt Circle	No. of Holes	Hole Dia.	Flange O.D.	Bolt Circle	No. of Holes	Hole Dia.	150# Rings Wt./#	300# Rings Wt./#		
1 1-1/4	4.25 4.625	3.125 3.5	4 4	.625 .625	4.875 5.25	3.5 3.875	4 4	.750 .750	1.9 2.4	2.9 3.0	10 12	16.0 19.0	14.25 17.0	12 12	1.0 1.0	17.5 20.5	15.25 17.75	16 16	1.125 1.25	17.0 24.1	23.0 31.3		
1-1/2 2	5.0 6.0	3.875 4.75	4 4	.625 .75	6.125 6.5	4.5 5.0	4 8	.875 .75	2.6 3.6	4.4 4.3	14 16	21.0 23.5	18.75 21.25	12 16	1.125 1.125	23.0 25.5	20.25 22.5	20 20	1.25 1.375	26.8 32.1	37.0 45.0		
2-1/2 3	7.0 7.5	5.5 6.0	4 4	.75 .75	7.5 8.25	5.875 6.625	8 8	.875 .875	5.3 5.6	5.5 6.0	18 20	25.0 27.5	22.75 25.0	16 20	1.25 1.25	28.0 30.5	24.75 27.0	24 24	1.375 1.375	33.6 35.9	58.0 67.0		
3-1/2 4	8.5 9.0	7.0 7.5	8 8	.75 .75	9.0 10.0	7.25 7.875	8 8	.875 .875	6.5 7.3	7.0 10.0	22 24	29.5 32.0	27.25 29.5	20 20	1.375 1.375	33.0 36.0	29.25 32.0	24 24	1.625 1.625	38.5 47.3	80.0 91.0		
5 6	10.0 11.0	8.5 9.5	8 8	.875 .875	11.0 12.5	9.25 10.625	8 12	.875 .875	7.9 9.1	11.6 14.5	30 36	38.75 46.0	36.0 42.75	28 32	1.375 1.625	43.0 50.0	39.25 46.0	28 32	2.0 2.25	66.0 85.3	120.0 140.0		
8	13	11.75	8 8	.875	15.0	13.0	12	1.0	14.0	19.6													

Table 3: Navy Drilling Specifications

**MIL-F-20042C-50LB
MIL-F-20042C-150LB
Bu Ships Drawing B-176**

Joint Size (inches)	O.D.	B.C.	No. of Holes	Hole Dia.
1/4	3-1/4	2-1/8	3	9/16
3/8	3-3/8	2-1/4	3	9/16
1/2	3-9/16	2-7/16	3	9/16
3/4	3-13/16	2-11/16	4	9/16
1	4-1/4	3-1/8	4	9/16
1-1/4	4-1/2	3-3/8	4	9/16
1-1/2	5-1/16	3-15/16	6	9/16
2	5-9/16	4-7/16	6	9/16
2-1/2	6-1/8	5	6	9/16
3	6-5/8	5-1/2	8	9/16
3-1/2	7-3/16	6-1/16	8	9/16
4	7-11/16	6-9/16	8	9/16
4-1/2	8-3/16	7-1/16	10	9/16
5	9-1/16	7-13/16	10	11/16
5-1/2	9-9/16	8-5/16	10	11/16
6	10-1/8	8-7/8	12	11/16
6-1/2	10-5/8	9-3/8	12	11/16
7	11-5/16	10	12	11/16
7-1/2	11-7/8	10-9/16	12	11/16
8	12-3/8	11-1/16	14	11/16
8-1/2	12-15/16	11-5/8	14	11/16
9	13-15/16	12-3/8	14	13/16
9-1/2	14-1/2	12-15/16	14	13/16
10	15	13-7/16	15	13/16
11	16-9/16	15	16	13/16
12	17-5/8	16-1/16	18	13/16
14	19-1/8	17-3/8	19	15/16
15	25-1/8	18-3/8	20	15/16
16	21-3/16	19-7/16	20	15/16
18	23-1/4	21-1/2	22	15/16
20	25-13/16	23-13/16	24	1-1/16
22	27-7/8	25-7/8	26	1-1/16
24	30	28	28	1-1/16
25	31-1/2	29-1/4	29	1-3/16
26	32-9/16	30-5/16	30	1-3/16
28	34-11/16	32-7/16	32	1-3/16
30	36-13/16	34-9/16	35	1-3/16
32	39	36-3/4	36	1-3/16
33	40	37-3/4	36	1-3/16
34	41	38-3/4	36	1-3/16
35	42-7/8	40-3/8	36	1-5/16
36	43-7/8	41-3/8	36	1-5/16
38	46-1/8	43-5/8	36	1-5/16
40	48-1/8	45-5/8	36	1-5/16
42	50-1/4	47-3/4	38	1-5/16
46	54-1/2	52	40	1-5/16

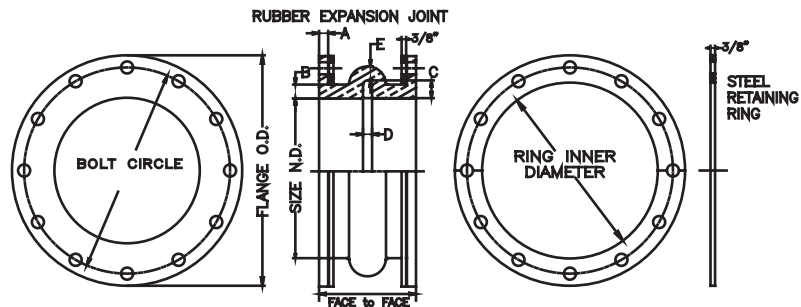

SUPER-FLEX STYLES 1000, 1100 AND 1200

WIDE-ARCH EXPANSION JOINT

SUPER-FLEX STYLE 1000

The Super-Flex 1000 provides double arch movements utilizing a single low profile wide arch. Manufactured utilizing tire industry technology the style 1000 has been designed to provide greater strength and pressure capabilities. The construction combines woven polyester fabric and reinforced with wire to create a product with superior performance characteristics.

The wide self-flushing arch provides more movement than a traditional spool type joint. When built with a filled arch for smooth bore service, (such as slurry applications) the movements are one half of the single open arch spool type joints. The double reinforced construction gives longer life expectancy and is also available in a full range of elastomers to enable multi-purpose applications.

The primary difference between the Style 1000 and Style 1100 is in the manufacturing process.

The 1000 is hand-wrapped to allow for design variations including offsets, non-standard face to face dimensions, multi-arch configurations and special flanges or drillings while still offering wide arch movement.

The Style 1000 is Available in These Elastomers and Constructions:		
Clorobutyl EPDM Gum Hypalon	Neoprene Nitrile SBR Silicone Viton® Flourel®	Multi-Arch Offset Special Ends Alternative Drilling

Optional Liners and covers are available

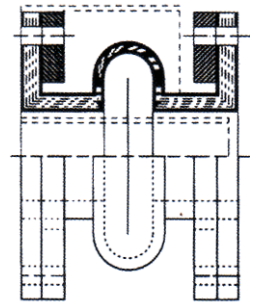

SUPER-FLEX STYLE 1100

Unaflex's® 1100 series has been designed to compete with the imports in terms of cost, and out perform the imports with a product that's made in America. The movements and benefits match the Style 1000 (above), if you don't need the customization options of the Style 1000.....the Style 1100 is a value packed expansion joint.

The cover has been formulated with an ozone and temperature resistant compound which prevents the Style 1100 from cracking unlike the imports. This new manufacturing technology has provided a product that has excellent performance at competitive price.

Due to the molded construction all face to face dimensions are standard. Engineered to withstand full vacuum and high pressure, (see next page). The Style 1100 is an excellent performer with a super price. Specify Super-Flex!

This drawing shows the 1100 Style construction. A wide self flushing arch allows greater movement and flexibility. Available in sizes from 2" to 36". See next page for dimensions and movement details. Optional liners and covers are available.

This drawing shows the 1100 Style construction. A wide self flushing arch allows greater movement and flexibility. Available in sizes from 2" to 36". See next page for dimensions and movement details. Optional liners and covers are available.

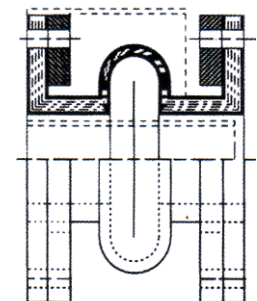



Complete with built-on
150 lb. retaining rings

SUPER-FLEX 1200 WIDE-ARCH EXPANSION JOINT

- Molded wide arch design
- Greater motion capability from wider arch
- Less force to compress
- Standard 150 lb. ANSIB 16.1 flange drilling
- Standard face-to-face dimensions
- Vacuum 26"hg

Size, Movement, Pressure, Weight and Drilling Chart

Size N.D. Length (in.)	Bolt Circle	Drilling Number of Holes	Size of Holes	Pressure P.S.I.G.	Movement Capacity				Expansion Joint Weight (lbs.)
					Axial		Deflection		
					Comp.	Elong.	Lateral	Angular	
2x6	4.75	4	.75	250	1-3/4	3/4	3/4	35	9
2.5x6	5.5	4	.75	250	1-3/4	3/4	3/4	30	10
3x6	6.0	4	.75	250	1-3/4	3/4	3/4	30	12
4x6	7.5	8	.75	250	1-3/4	3/4	3/4	25	16
5x6	8.5	8	.875	250	1-3/4	3/4	3/4	25	20
6x6	9.5	8	.875	250	1-3/4	3/4	1	20	21
8x6	11.75	8	.875	250	1-3/4	3/4	1	20	30
10x8	14.25	12	1.0	250	1-3/4	3/4	1	15	45
12x8	17.00	12	1.0	250	1-3/4	3/4	1	15	65

Available Styles, Materials and Temperatures

Style Number	Type of elastomer		Maximum Operating Temperature °F	F.S.A. Material Class
	Cover/Outside	Tube/Inside		
1200CC	Butyl	Butyl	250°F	Special II
1200EE	EPDM	EPDM	250°F	Special II
1200NN	Neoprene	Neoprene	230°F	Std. II
1200BN	Neoprene	Nitrile	230°F	Std. II

Applications:

- Control pipe movements and stress
- Reduce system noise
- Isolate mechanical vibration
- Compensate alignment/offset
- Eliminate electrolysis
- Protect against start-up surge force
- Absorption machine
- Chiller
- Cooling towers
- Compressors
- Blowers
- Fan

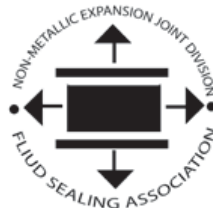

SUPER-FLEX STYLE 1000 AND 1100 EXPANSION JOINTS

Dimensions for Wide Arch

We do not use marginal constructions which reduce safety factors and cause pressure reductions with slight operating pressure increases. All Supreme Expansion Joints have a minimum 4 to 1 safety factor at rated operating temperatures and pressures. Note: Maximum diameter for Style 1100 is 36"

Joint Size N.D.	Face-to-Face	Flange O.D.	Bolt Circle Dia.	No. of Bolts	Bolt Hole Dia.	Ring I.D.	Movements					Weights			Control Units Lbs.					
							A	B	C	D	E	Style 1000 Max. P.S.I	Style 1100 Max. P.S.I	Axial Compression		Axial Extension	Trav. Deflection	Joint Weight/Lbs.	Retaining Rings/Lbs.	
1/2	6	3-1/2	2-3/8	4	9/16	1-1/4	1/2	7/8	1	1-3/4	3/8	225	225	1-3/4	3/4	3/4	1	1.5	1.5	6
3/4	6	3-7/8	2-3/4	4	9/16	1-5/8	1/2	7/8	1	1-3/4	3/8	225	225	1-3/4	3/4	3/4	1.5	2	2	6
1	6	4-1/4	3-1/8	4	5/8	1-7/8	9/16	7/8	1	1-3/4	3/8	225	225	1-3/4	3/4	3/4	2	2.25	2.25	6
1-1/4	6	4-5/8	3-1/2	4	5/8	2-1/8	9/16	7/8	1-1/8	1-3/4	7/16	225	225	1-3/4	3/4	3/4	2.5	2.5	6	
1-1/2	6	5	3-7/8	4	5/8	2-3/8	9/16	7/8	1-1/8	1-3/4	7/16	225	225	1-3/4	3/4	3/4	3	3	6	
2	6	6	4-3/4	4	3/4	3-1/8	9/16	29/32	1-1/4	1-3/4	1/2	225	225	1-3/4	3/4	3/4	4	4	7	
2-1/2	6	7	5-1/2	4	3/4	4-1/8	9/16	29/32	1-1/4	1-3/4	1/2	225	225	1-3/4	3/4	3/4	4.5	5.5	7	
3	6	7-1/2	6	4	3/4	4-5/8	9/16	29/32	1-1/4	1-3/4	1/2	225	225	1-3/4	3/4	3/4	5.5	6	7	
4	6	9	7-1/2	8	3/4	5-7/8	9/16	7/8	1-1/4	1-3/4	1/2	225	225	1-3/4	3/4	3/4	8	7.5	8	
5	6	10	8-1/2	8	7/8	6-7/8	9/16	7/8	1-1/4	1-3/4	1/2	225	225	1-3/4	3/4	3/4	9	8	8	
6	6	11	9-1/2	8	7/8	7-7/8	5/8	1	1-1/4	1-3/4	1/2	225	225	1-3/4	3/4	1	11	9	9	
8	6	13-1/2	11-3/4	8	7/8	9-7/8	3/4	1	1-1/2	1-3/4	5/8	225	225	1-3/4	3/4	1	15	12	12	
10	8	16	14-1/4	12	1	12-1/8	3/4	1-5/32	1-1/2	1-3/4	11/16	225	225	1-3/4	3/4	1	23	16	16	
12	8	19	17	12	1	14-1/2	3/4	1-5/32	1-1/2	1-3/4	11/16	225	225	1-3/4	3/4	1	34	22	16	
14	8	21	18-3/4	12	1-1/8	16-1/2	7/8	1-5/32	2	1-3/4	3/4	225	225	1-3/4	3/4	1	40	25	20	
16	8	23-1/2	21-1/4	16	1-1/8	18-1/2	7/8	1-5/32	2	1-3/4	3/4	160	160	1-3/4	3/4	1	47	27	20	
18	8	25	22-3/4	16	1-1/4	20-1/2	7/8	1-5/32	2	1-3/4	3/4	160	160	1-3/4	3/4	1	56	29	21	
20	8	27-1/2	25	20	1-1/4	22-5/8	1	1-5/32	2	1-3/4	25/32	130	130	1-3/4	3/4	1	67	35	21	
22*	10	29-1/2	27-1/4	20	1-3/8	24-5/8	1	1-5/32	2	1-3/4	25/32	130	-	1-3/4	3/4	1	70	44	32	
24	10	32	29-1/2	20	1-3/8	26-5/8	1	1-5/32	2	1-3/4	25/32	130	130	1-3/4	1	1	79	46	32	
26*	10	34-1/4	31-3/4	24	1-3/8	28-7/8	1	1-3/16	2-1/4	1-3/4	13/16	110	-	1-3/4	1	1	100	50	32	
28*	10	36-1/2	34	28	1-3/8	30-7/8	1	1-3/16	2-1/4	1-3/4	13/16	110	-	1-3/4	1	1	102	55	32	
30	10	38-3/4	36	28	1-3/8	32-7/8	1	1-3/16	2-1/4	1-3/4	13/16	95	100	1-3/4	1	1	117	58	32	
34*	10	43-3/4	40-1/2	32	1-5/8	37	1	1-3/16	2-1/4	1-3/4	13/16	95	-	1-3/4	1	1	122	91	43	
36	10	46	42-3/4	32	1-5/8	39	1	1-3/16	2-1/4	2-1/4	13/16	90	100	2-1/4	1	1	143	99	43	
40*	10	50-3/4	47-1/4	36	1-5/8	43	1	1-3/16	2-1/4	2-1/4	13/16	90	-	2-1/4	1	1	173	108	43	
42	12	53	49-1/2	36	1-5/8	45-1/4	1-3/16	1-1/4	2-1/2	2-1/4	29/32	90	-	2-1/4	1	1	193	110	44	
44*	12	55-1/4	51-3/4	40	1-3/4	47-1/4	1-3/16	1-1/4	2-1/2	2-1/4	29/32	90	-	2-1/4	1	1	198	136	44	
48	12	59-1/2	56	44	1-5/8	51-1/4	1-3/16	1-1/4	2-1/2	2-1/4	29/32	90	-	2-1/4	1	1	211	154	87	
50*	12	61-3/4	58-1/4	44	1-7/8	53-1/4	1-3/16	1-3/8	2-1/2	2-1/4	29/32	85	-	2-1/4	1	1	240	163	87	
54	12	66-1/4	62-3/4	44	2	57-1/4	1-3/16	1-3/8	2-1/2	2-1/4	29/32	85	-	2-1/4	1-1/4	1	265	185	87	
56*	12	68-3/4	65	48	2	59-1/4	1-3/16	1-3/8	2-1/2	2-1/4	29/32	85	-	2-1/4	1/4	1	288	203	87	
60	12	73	69-1/4	52	2	63-1/4	1-3/16	1-3/8	2-1/2	2-1/4	29/32	85	-	2-1/4	1-1/4	1	309	215	87	
62*	12	75-3/4	71-3/4	52	2	65-1/4	1-3/16	1-3/8	2-1/2	2-1/4	29/32	85	-	2-1/4	1-1/4	1	325	230	87	
66*	12	80	76	52	2	69-1/4	1-3/16	1-3/8	2-1/2	2-1/4	29/32	85	-	2-1/4	1/4	1	350	255	87	
72	12	86-1/2	82-1/2	60	2	75-1/4	1-3/16	1-3/8	2-1/2	2-1/4	29/32	85	-	2-1/4	1-1/4	1	385	300	87	
78	12	93	89	64	2-1/8	81-1/4	1-3/16	1-3/8	2-1/2	2-1/4	29/32	85	-	2-1/4	1-1/4	1	410	325	103	
84	12	99-3/4	95-1/2	64	2-1/4	87-1/2	1-3/16	1-3/8	2-1/2	2-1/4	29/32	85	-	2-1/4	1/4	1	435	350	113	
96	12	113-3/4	108-1/2	68	2-1/2	99-3/8	1-3/16	1-3/8	2-1/2	2-1/4	29/32	85	-	2-1/4	1-1/4	1	460	375	125	
102	12	120	114-1/2	72	2-5/8	105-1/2	1-3/16	1-3/8	2-1/2	2-1/4	29/32	85	-	2-1/4	1-1/4	1	485	400	137	
108	12	126-3/4	120-3/4	72	2-5/8	111-1/2	1-3/16	1-3/8	2-1/2	2-1/4	29/32	85	-	2-1/4	1-1/4	1	510	425	139	
120	12	140-1/4	132-3/4	76	2-7/8	123-1/2	1-3/16	1-3/8	2-1/2	2-1/4	29/32	85	-	2-1/4	1/4	1	535	560	151	
132	12	153-3/4	145-3/4	80	3-1/8	135-1/2	1-3/16	1-3/8	2-1/2	2-1/4	29/32	85	-	2-1/4	1-1/4	1	560	585	163	
144	12	167-1/4	158-1/4	84	3-3/8	147-1/2	1-3/16	1-3/8	2-1/2	2-1/4	29/32	85	-	2-1/4	1-1/4	1	585	610	176	

“UNASPHERE” STYLE 800 EXPANSION JOINTS

Precision molded of neoprene and nylon, these units require less force to move than conventional joints, allowing maximum deflection, elongation and compression. Their design is stronger than other configurations because of the spherical shape. The smooth flow arch reduces turbulence and allows quiet flow without sediment build-up. **All three styles also available in EPDM and nitrile with neoprene cover.**



Design Data:

Pressure—16” HG Vacuum, 225 PSIG

Temperature—20°F to 180°F.

Size, Movement, Pressure, Weight and Drilling Data

Size (in.)	Face-to-Face (in.)	Flange Thick (in.)	No. of Holes	Thread Size	Allowable Movement			
					Lateral Deflect (in.)	Elongation (in.)	Compression (in.)	Angular Movement
2	6	5/8	4	5/8-11NC	±1/2	3/8	1/2	15
2-1/2	6	11/16	4	5/8-11NC	±1/2	3/8	1/2	15
3	6	11/16	4	5/8-11NC	±1/2	3/8	1/2	15
4	6	11/16	8	5/8-11NC	±1/2	3/8	5/8	15
5	6	13/16	8	3/4-10NC	±1/2	3/8	5/8	15
6	6	7/8	8	3/4-10NC	±1/2	3/8	5/8	15
8	6	7/8	8	3/4-10NC	±1/2	3/8	5/8	15
10	8	15/16	12	7/8-9 NC	±3/4	1/2	3/4	15
12	8	15/16	12	7/8-9 NC	±3/4	1/2	3/4	15



“TWIN-SPHERE” STYLE 802

The Twinsphere is precision molded of neoprene and nylon tire cord. The double arch design allows for greater movement four different ways and provides for a non-turbulent flow. Angular movement up to 30° is obtainable with its highly flexible design. Rated for 225 PSI WP at 170°F. Pressure is reduced at higher temperatures. Vacuum Rating to 26” HG.

Size (in.)	Face-to-Face (in.)	Comp.	Elong.	Lateral Movement	Angular Movement
2	7	.9	.28	.79	30
2-1/2	7	.9	.28	.79	30
3	7	.9	.28	.79	30
4	9	1.32	.45	.98	30
5	9	1.32	.45	.98	30
6	9	1.32	.45	.98	30
8	13	1.78	.58	1.18	30
10	13	1.78	.58	1.18	30
12	13	1.78	.58	1.18	30

“TWIN-SPHERE” STYLE 803

This highly capable, low-cost expansion joint is available for smaller diameter piping systems found in power plants, chemical plants, waterworks, sewage treatment plants and private residences, etc. The Twin-Sphere provides excellent vibration absorption and stress relief in a light, compact construction.



Operating Pressure: 150 PSI. Vacuum Rating: 15” HG. Diameters are available in 3/4”, 1”, 1-1/4”, 1-1/2” and 2”

“MULTI-PURPOSE” PTFE (TEFLON®) EXPANSION JOINTS

Unalox® Styles 112A, 113A and 115A Solid TEFLON® Molded Expansion Joints were developed to withstand higher pressures and temperatures. Their design allows a shorter face-to-face dimension, making them ideal for use where space is limited. They are lightweight and corrosion resistant. Available in sizes 1” to 12” Nominal Diameter and for temperature ratings from -300°F to +400°F.

Comprehensive technical data charts can be accessed by visiting www.ptfe-expansion-joints.com.



EXPANSION JOINT DATA

Style 112A (2 Convolutions)					Style 113A (3 Convolutions)				Style 115A (5 Convolutions)				
Nom. Dia. I.D.	Neutral Length	Movement (In.)		Weight Lbs.	Neutral Length	Movement (In.)		Weight Lbs.	Neutral Length	Movement (In.)		Weight Lbs.	
		Axial	Lateral			Axial	Lateral			Axial	Lateral		
1.0	1.375	0.250	.125	2	1.750	.500	.250	2	3.000	0.500	.500	2	
1.25	1.375	0.250	.125	5	1.810	.500	.250	5	2.670	0.394	.470	5	
1.50	1.375	0.250	.125	3	2.000	.500	.250	4	3.500	0.750	.500	3	
2.00	1.563	0.250	.125	7	2.750	.750	.375	8	4.000	1.000	.500	7	
2.50	2.250	0.313	.125	10	3.188	.750	.375	11	4.600	0.980	.510	10	
3.00	2.250	0.375	.188	10	3.625	1.000	.500	13	5.000	1.000	.500	10	
4.00	2.625	0.500	.250	18	3.625	1.000	.500	19	5.250	1.250	.625	18	
5.00	3.250	0.500	.250	24	4.000	1.000	.500	25	6.000	1.250	.625	24	
6.00	2.750	0.500	.250	29	4.000	1.125	.563	30	6.000	1.250	.625	29	
8.00	4.00	0.500	.250	47	6.000	1.125	.563	48	8.000	1.250	.625	47	
10.00	5.250	0.500	.250	64	7.000	1.188	.500	60	8.750	1.250	.625	64	
12.00	6.000	0.500	.250	115	7.875	1.188	.625	77	9.000	1.375	.688	115	

****Safety Shields Are Recommended**

For information on the “E” Series, please visit our website: www.unaflex.com and click PTFE Expansion Joints

Unalox® Performance curve of working pressures vs. operating temperatures (all sizes)

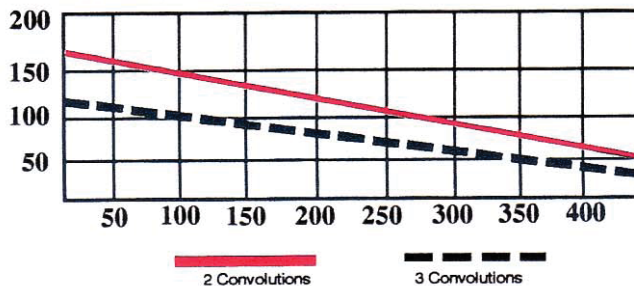

Vacuum Service Maximum temperature for full vacuum (29.9 HG.)	
Two Convolutions	
1” to 6” 8” to 10”	400°F 250°F
12”	150°F
Three Convolutions	
1” to 4” 5” to 6” 8” to 12”	400°F 300°F 125°F

Note: For greater pressure or safety requirements than shown, special Viton®/Kevlar® overlays are available. Optional flow liners are available in TEFLON®, Elastomeric, Stainless Steel and Nickel Alloys. Consult our engineering department for further details.

Vacuum: Vacuum support rings can be added in the top (crest) of the convolution for full vacuum at 400°F for sizes 6” and larger. Support rings can be manufactured from various types of Stainless Steel, Tantalum and Nickel Alloys.

Teflon® is a registered Trademark of DuPont. Only DuPont makes Teflon®

THE INDUSTRY'S MOST COMPLETE LINE OF EXPANSION JOINTS

UNAFLEX "RADI-FLEX" ELBOW EXPANSION JOINTS

"RADI-FLEX" Joints are designed to reduce noise and vibration in angled installments. Spiraled steel wires are embedded in the walls from flange-to-flange for extra strength. Standard construction is of rubber tube with polyester reinforcement with a synthetic cover. Temperature ranges up to 180°F can be handled. High temperature construction using a butyl tube with polyester reinforcement and a butyl cover allow use from 180°F to 250°F. Also available in Neoprene, Buna N, Hypalon and EPDM (Nordel). Maximum pressures for standard units are: 2" and 3"-90 psi; 4" to 6"-80 psi; 8" to 10"-70 psi; and 12" to 14"-60 psi.

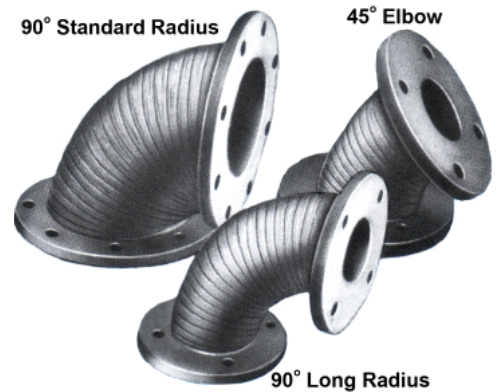

Unaflex® "RADI-FLEX" Elbow Joints Dimensions								
Size N.D. (in.)	Flange Thick. A (in.)	B Flange O.D. (in.)	C C to F 90° STD. (in.)	C C to F 90° L.R. (in.)	C C to F 45° (in.)	Allowable Movement		
						Comp. (in.)	Deflect. (in.)	Ext. (in.)
2	1	6	4-1/2	6-1/2	2-1/2	1/2	1/2	1/2
2-1/2	1	7	5	7	3	1/2	1/2	1/2
3	1-1/8	7-1/2	5-1/2	7-3/4	3	1/2	1/2	1/2
4	1-1/8	9	6-1/2	9	4	1/2	1/2	1/2
5	1-1/8	10	7-1/2	10-1/4	4-1/2	3/4	3/4	3/4
6	1-1/8	11	8	11-1/2	5	3/4	3/4	3/4
8	1-1/8	13-1/2	9	14	5-1/2	3/4	3/4	3/4
10	1-1/4	16	11	16-1/2	6-1/2	3/4	3/4	3/4
12	1-1/4	19	12	19	7-1/2	3/4	3/4	3/4
14	1-1/4	21	14	22-1/2	7-1/2	3/4	3/4	3/4

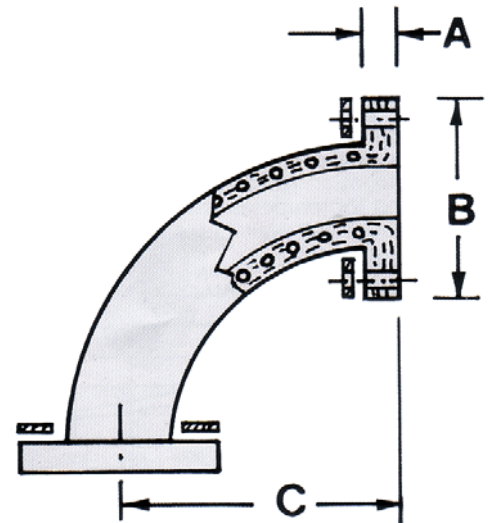

Notes:

1. Flange size dimensions conforms to ANSI-Class 150# drilling
2. Split rings are 3/8" Galvanized Steel Plate
3. Center-to-face dimensions are subject to ±1/4" tolerance

CROSSES, TEES AND SPECIAL PRODUCTS



Unaflex® "RADI-FLEX" Crosses and Tees are custom manufactured to your specifications with all features of our Elbow Expansion Joints. **Call for further information regarding available constructions and delivery schedules.**

Special Products include:

- Pipe Clamp Sleeves
- Wellpoint Sleeves
- Endless belts for use on equipment
- Rubber Tubing
- Vacuum Sleeve Connectors
- Exhaust Connectors
- Suction Box Hose for Papermills
- Dredge Sleeves
- Slurry Connectors
- Food Handling Connectors
- Acid Hose Connectors
- Pre-Formed Hose
- Pinch Valve Bodies

“MIGHTY-SPAN” RUBBER FLUE DUCT EXPANSION JOINTS

Unaflex® “MIGHTY-SPAN” Style 600 Rubber Flue Duct Expansion Joints are designed to handle hot air or gasses in industrial duct work, as well as those generated by power plant and pollution control equipment. They are custom constructed of rubber and fabric to absorb thermal movements and vibration in duct work and to aid in the elimination of noises caused by scrubber equipment and mechanical dust collectors.

MIGHTY-SPAN is capable of handling any combination of large movements which might occur in a ducting system due to thermal expansion. MIGHTY-SPAN creates almost no load on damper and fan interfacing flanges, thus providing much needed protection in these critical areas.

A wide range of elastomers and fabric substrates are available to provide maximum resistance to corrosion and high temperature capabilities as well as white FDA food grade elastomers. Let Unaflex® assist you in selecting the MIGHTY-SPAN product for your application.



CONFIGURATIONS

- Square, rectangular or round in any size. Standard construction “U” shape, 9” face-to-face, 3” flange.
- Arch shapes also available. One-piece body 5/16” thick. Steel retaining rings are provided (send drawing or call Unaflex® for quotation.)



CHOICE OF MATERIAL

Fabric Reinforcement

Style 600 Joints may be constructed of *Nomex (to 400°F), fiberglass or polyester cloth impregnated with one of the following:

Tube and Cover

Neoprene—Resistant to heat, adverse weather, ozone and fuel gasses. Impervious to fats, oils, greases and other petroleum products. For use up to 250°F.

Chlorobutyl—An elastomer with all of the above advantages of neoprene, with the exception of its inability to withstand oil. For use up to 300°F.

***Viton®/**Fluorel®**—In addition to providing all of the properties of neoprene, Fluorel is resistant to mineral acids and usable in 400°F applications.

Silicone—A high-quality elastomer recommended for all environments except those with sulfur gas (SO₂ or SO₃). For use in -70° to 500°F applications.

*DuPont trademark **3M trademark.

U-Type compression and elongation formulas

Lateral Elongation= 2 lbs. per foot of perimeter per 1/16” of movement. For example: 2’ x 2’ I.D.= 8’ perimeter deflection= 1” = 16/16. 2 lbs. x 8” x 16”=256 lbs.

Axial Compression = 2.2 lbs. per foot of perimeter per 1/16” of movement. For example: 2’ x 2’ I.D. = 8’ perimeter deflection = 1” = 16/16. 2.2 lbs. x 8” x 16” = 282 lbs.

Environmental Conditions			
Elastomer	Usable to°F	Recommended for Use In	
		Oils, Grease	Ozone & Flue Gases
Neoprene	250	good	good
Chlorobutyl	300	--	good
*Viton®	400	good	good
Silicone	500	good	--

Recommended Service	
Pressure	to 3.0 psig, max
Vacuum	6.12” Hg, 83” Hg
Compression*	2”
Extension*	1/2”
Transverse	1-1/2”

"SUPER-QUIET" RUBBER VIBRATION AND SOUND ABSORBERS

STYLES 2150 AND 2250

Unaflex® "Super-Quiet" Styles 2150 (150 psi WP) and 2250 (250 psi WP) vibration and sound absorbers are specially designed lengths of rubber pipe with factory attached ferrules for pipe and other connections involving standard IPT. They eliminate vibration between pump and pipe lines either for suction or discharge.



For Working Pressures to 150 PSI		
	For Water Service to 180°F	For Water Service from 180 to 250°F Max.
Ferruled Coupling	2150	2150 H.T.
Flanged End	3150	3150 H.T.
For Working Pressures to 250 PSI		
	For Water Service to 180°F	For Water Service from 180 to 250°F Max.
Ferruled Coupling	2250	2250 H.T.
Flanged End	3250	3250 H.T.

*Style 2150 and 2250 Dimensions			
Pipe Size N.D. (in.)	Standard Overall Length (in.)	Pipe Size N.D. (in.)	Standard Overall Length (in.)
3/4	12	2	24
1	18	2-1/2	24
1-1/4	18	3	36
1-1/2	18	4	36

IMPORTANT: Unaflex® Vibration and Sound Absorbers are not designed to accommodate the movement in a piping system caused by temperature change or other conditions. See Spool-Type Expansion Joints for such applications.

"SUPER-QUIET" STYLES 3150 AND 3250

Unaflex® "Super-Quiet" Styles 3150 (150 psi WP) and 3250 (250 psi WP) sound absorbers are built with molded rubber flanged ends with bolt holes that accommodate standard steel flanges. Available with or without helical wire reinforcement. Special tubes can be made to meet unique requirements for either suction or discharge.



Specify Unaflex® Flexible Connectors		
Style 3150	150# W.P.	180°F
Style 3250	250# W.P.	180°F
Style 3150 HT	150# W.P.	250°F
Style 3250 HT	250# W.P.	250°F

Percentage of Reduction of Vibration Input with Frequency and Pressure as Compared to Steel Pipe

Center Freq. Hz	8" I.D. x 24" F-F Vibration Joint		
	10 psig	50 psig	80 psig
440	87%	91%	93%
68	95%	96%	99%
125	98%	99%	99%
250	96%	97%	99%
500	91%	93%	94%
1000	82%	91%	96%
2000	99%	99%	99%
4000	99%	99%	99%
8000	97%	97%	98%

EXAMPLE: If a steel piping system had a major vibration frequency of 1,000 Hz at 50 PSIG and 8" rubber expansion joint was installed in the pipeline, the percentage of reduction of vibration would be 96%. Above data taken from the Fluid Sealing Association Handbook.

Joint Size N.D.(in.)	Face-to-Face		Style 3150 (Conforms to ANSI 150# Drilling)						Style 3250 (Conforms to ANSI 300# Drilling)					
	Min (in.)	Max (in.)	Ring I.D. (in.)	Flange Diam. (in.)	Thick. (in.)	Bolt Cir. Diam. (in.)	No.	Bolt Holes Diam. (in.)	Ring I.D. (in.)	Flange Diam. (in.)	Thick. (in.)	Bolt Cir. Diam. (in.)	No.	Bolt Holes Diam. (in.)
1-1/2	12	24	2-7/8	5	11/16	3-7/8	4	5/8	2-7/8	6-1/8	23/32	4-1/2	4	7/8
2	12	24	3-5/8	6	11/16	4-3/4	4	3/4	3-5/8	6-1/2	23/32	5	8	3/4
3	12	36	4-5/8	7-1/2	27/32	6	4	3/4	4-5/8	8-1/4	27/32	6-5/8	8	7/8
4	12	36	5-7/8	9	27/32	7-1/2	8	3/4	5-7/8	10	7/8	7-7/8	8	7/8
5	12	36	6-7/8	10	15/16	8-1/2	8	7/8	6-7/8	11	15/16	9-1/4	8	7/8
6	18	36	7-7/8	11	31/32	9-1/2	8	7/8	7-7/8	12-1/2	15/16	10-5/8	12	7/8
8	24	48	9-7/8	13-1/2	31/32	11-3/4	8	7/8	9-7/8	15	1-1/16	13	12	1
10	24	48	12-1/8	16	1-3/16	14-1/4	12	1	12-1/8	17-1/2	1-11/32	15-1/4	16	1-1/8
12	24	48	14-1/2	19	1-7/32	17	12	1	14-1/2	20-1/2	1-11/32	17-3/4	16	1-1/4

UNAFLEX[®] LLC.

Excellence in Manufacturing

ISO 9001:2008 CERTIFIED

CALL TOLL FREE: 1-800-327-1286



Visit www.unaflex.com to download
our full line of product catalogs

STANDARD WARRANTY

All merchandise sold by UNAFLEX[®] is subject to this Standard Warranty. Our products are warranted to be free from defects in material or workmanship. Our liability for breach of any and all warranties, expressed or implied, is limited to refunding our invoice price of the product, or at our option, to replacement of the product. If any product manufactured by UNAFLEX[®] is found by us to be defective either in material or workmanship, under proper usage and service, the invoice price will be refunded or at our option will be replaced free of charge including transportation charges, but not cost of installation. The refund of the invoice price or the replacement of the product is the maximum liability of the company. The sale of our products under any other warranty or guarantee, expressed or implied, is not authorized by the company.

Technical statements and engineering data in this catalog is the most accurate information available at the time of printing and are subject to change without notice. As UNAFLEX[®] does not supervise or control the use of our products, UNAFLEX[®] cannot be responsible for improper use or misapplication of catalog data.

3901 NE 12th Avenue • Pompano Beach, FL 33064

Mail: P.O. BOX 5088 • Ft. Lauderdale, FL 33310

TOLL FREE: 1-800-327-1286

Ph: 954.943.5002 • Fax: 954.941.7968

Factory Facilities in Anderson, SC. | Warehouse Facilities in Houston, TX