



# T-Line Valve<sup>®</sup>

T - 4 1   A N D   T - 4 3   P L U G   V A L V E S



**NEW**



Quality System Certificate

*Stainless Steel Armor Available*

Bulletin VT-17z

# T-Line Chemical Service Valve Features

**T**hese features have made Durco T-41 and T-43 valves the most preferred PTFE lined valves in the chemical process industries. Durco T-Line valves provide maximum corrosion resistance and the elimination of product contamination at a reasonable cost.

### New Alloy Options

Plug insert and body armor are also available in D4/316SS and other alloys.

#### Tapered Plug

Is grounded to body. Double D plug stem accepts most standard actuation equipment.

#### In-Line Adjustment

Stainless adjuster with rocker-arm design assures even stem seal pressure.

#### One Piece Ductile Iron Body

Is available in ANSI class 150 and 300 lb carbon steel body.

#### PFA Reverse Lip Diaphragm

Provides static and self-adjusting dynamic stem seal.

#### Stem Seal

At top of plug provides double protection against external stem leakage.

#### Typical applications include:

- Hydrochloric acid
- Sulfuric acid
- Hot rayon spin bath solution
- Waste acids
- Acid brine
- Other severe corrosives

#### Corrosion Resistant Coating

Is standard on body and top cap.

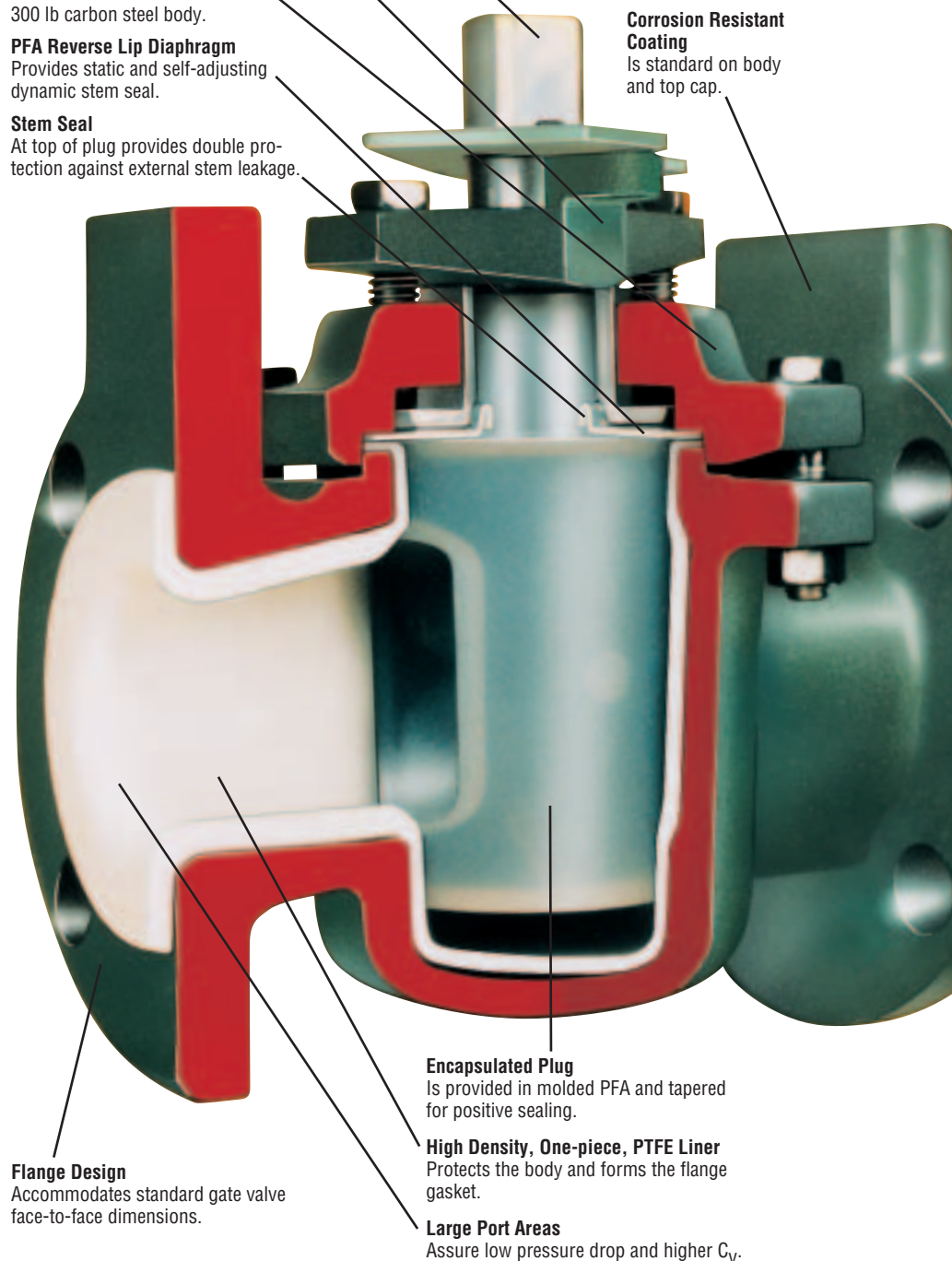

#### Flange Design

Accommodates standard gate valve face-to-face dimensions.

#### Encapsulated Plug

Is provided in molded PFA and tapered for positive sealing.

**High Density, One-piece, PTFE Liner**  
Protects the body and forms the flange gasket.

#### Large Port Areas

Assure low pressure drop and higher  $C_v$ .

# Benefits You'll Enjoy With Durco T-41 and T-43 Valves

**Solid one-piece PTFE lining in the body and on flange faces plus a PFA encapsulated plug maximizes corrosion resistance and virtually eliminates potential leak paths.**



A key design feature of T-41 and T-43 valves is the thick, one-piece continuous PTFE lining that covers all wetted surfaces in the body\*. PFA covering the plug extends up the stem through the top cap.

\*Note: 1/2 in (15 mm), 3/4 in (20 mm), 10 in (250 mm) and 12 in (300 mm) have PFA lined bodies.

**A dynamic self-adjusting, self-energized reverse lip, PFA diaphragm seal prevents stem leakage.**

Should line pressure force liquid to the stem seal area, the self-energizing reverse lip PFA diaphragm will be forced against the stem to prevent external leakage.

A sealing surface as much as 10x greater than other lined valves assures drop tight shut-off.

In addition to the large sealing area, sealing is both upstream and downstream and is totally independent of line pressure.

**You never replace valve seats, you only reseal the plug with a quick and easy in-line adjustment.**

An open-end wrench and a few seconds are the extent of your maintenance requirements. There are:

- No seats to replace
- No lengthy production disruption
- No piping disconnection
- No complicated, time-consuming maintenance procedures
- No hazards to personnel



*The PTFE linings assure non-sticking, easy turning valves that require no lubrication. The PFA plug seated in the PTFE lined body bore provides positive, drop tight shut-off in a quarter turn operation.*

## Available In Broad Size Range And Extended Pressure Class

- T-41 valves offered in sizes 1/2 in (15 mm) through 12 in (300 mm)
- T-43 valves offered in sizes 1 in (25 mm) through 6 in (150 mm)
- T-41 (Class 150) and T-43 (Class 300) ANSI face-to-face dimensions, flanged only
- Available with pneumatic or electric actuators for on-off or modulating "control" applications
- T-41 rated 180 psi (1240 kPa) @ 400°F, 250 psi (1724 kPa) @ 100°F
- T-43 rated 320 psi (2206 kPa) @ 400°F, 740 psi (5102 kPa) @ 100°F
- Outstanding Cv characteristics better than alternative valve designs in the more common sizes
- T-41 and T-43 valves are rated to 30 inches Hg vacuum, at ambient

# E-Z Turn T-Line Valves

**D**urco T-Line valves have significantly reduced torque which, in turn, has reduced stress on both piping and people.

For nearly 30 years, Durco T-Line valves have been the most preferred PTFE lined valves in the CPI for obvious reasons:

- They don't leak
- They seldom need maintenance and never require seat replacement. Design and manufacturing improvements, plus a new gear operator, have made Durco T-Line valves very easy to operate.
- They are available in more sizes with extended pressure class and higher temperature limits.

The T-Line has as much as ten times the sealing area as other lined valves and seals both up and downstream. Durco T-Line valves now provide a positive seal and E-Z Turn convenience.

Design and manufacturing improvements, plus new gear operator, have made Durco T-Line valves very easy to operate.

So, for leak-free, E-Z Turn performance in the toughest services, specify the best lined valve in the CPI...Durco T-Line valves.



**E-Z Turn is Available on 1 in (25 mm) thru 8 in (200 mm) T-Line Valves**

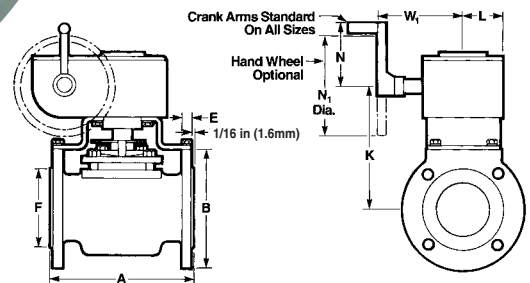

# Durco T-Line Control Valves

**Choose from a complete line of Automax Valve Automation Equipment for precise proportioning and on-off control...or we'll build a control package to your specification.**

V-Port T-Line valves are available in 1 in (25 mm) through 3 in (80 mm) sizes with  $C_v$  values of 1 through 66.

Standard Port T-Line valves are available in 1/2 in (15 mm) through 12 in (300 mm) sizes with  $C_v$  values of 5.6 through 3200.

Durco T-Line valves are readily adaptable for automatic operation because the torque is relatively constant and lubrication is not required.

Additional information about T-Line control valves can be found in Bulletin V-19, Durco Control Valves.

Flowserve's Automax Inc., a specialist in complete automation systems, markets a broad line of rack and pinion, heavy-duty, electric and linear actuators. In addition, a comprehensive line of engineered special control circuits, solenoid valves, limit switches, positioners and actuator mounting kits is offered.

This expertise in the rapidly growing control valve market provides a complementary product line to the other automation products offered by Flowserve's Fluid Control Group.

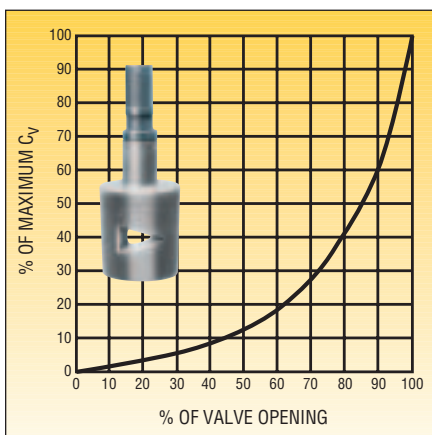

Typical characteristic curve for V-Port T-Line. For actual data consult Durco control valve technical manual for valve and actuator sizing.

# Technical Data

1 in (25 mm) thru 4 in (100 mm) T-Line Valves

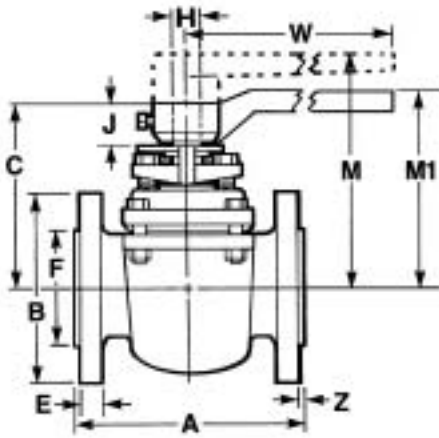

8 in (200 mm) T41-MAFS3-Mastergear

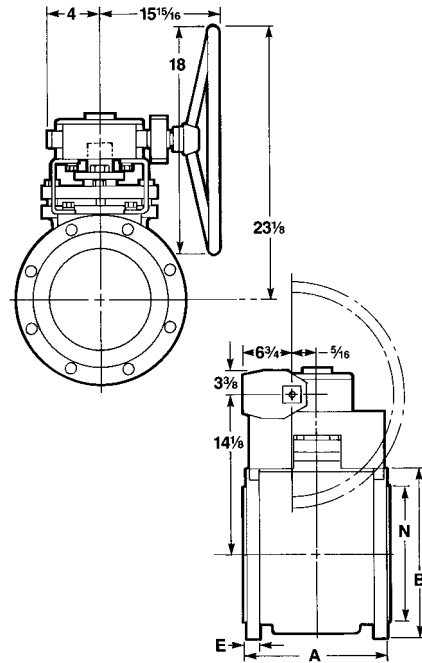

1 in (25 mm) thru 6 in (150 mm) E-Z Turn T-Line Valves

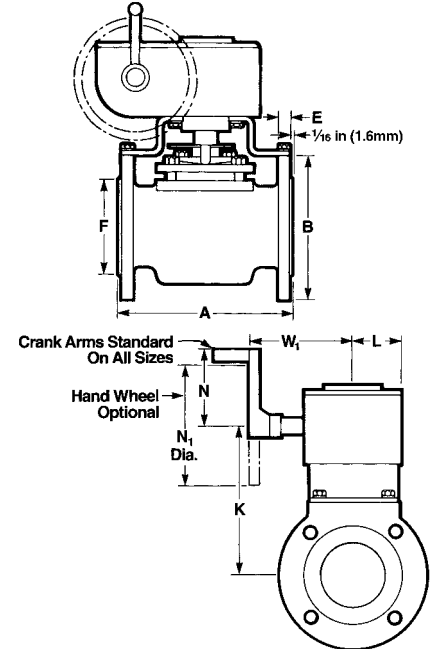

10 in (250 mm) thru 12 in (300 mm)

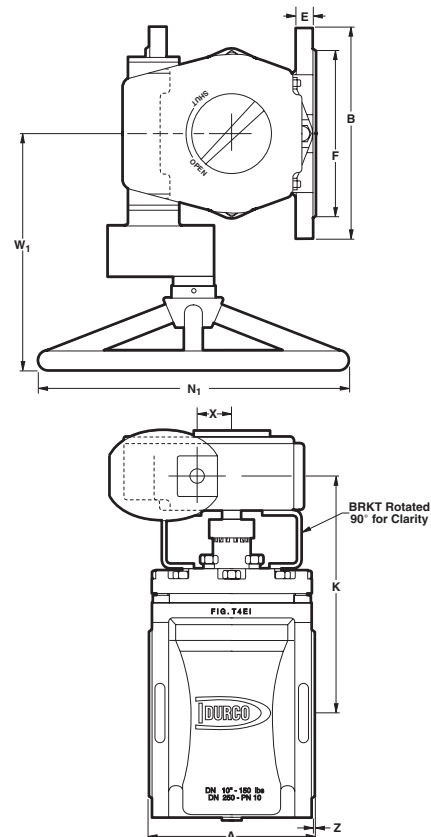
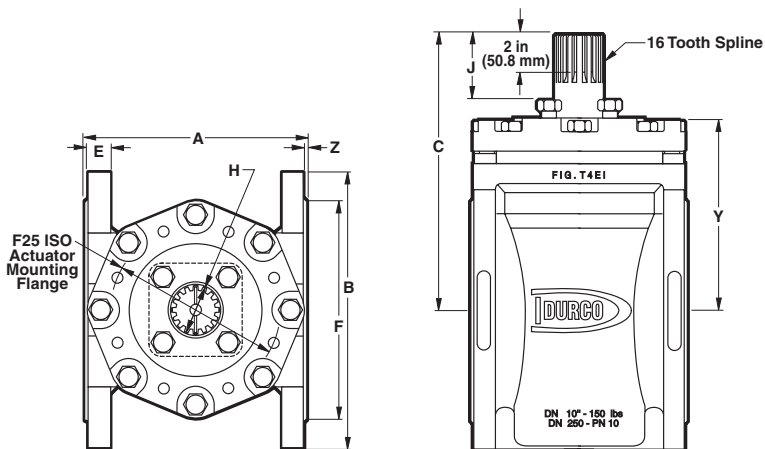

# Technical Data

Dimensions																																	
Valve Size in (mm)	Drilling Class 150			Drilling Class 300			A Class		B Class		C	E* Class		F	H	J	K		L		N		N <sub>1</sub>		W	W <sub>1</sub>	X	Y	Z	M1 Offset Design in (mm)	M High Hub in (mm)		
	No.	Size in (mm)	B.C. in (mm)	No.	Size in (mm)	B.C. in (mm)	150 in (mm)	300 in (mm)	150 in (mm)	300 in (mm)	in (mm)	150 in (mm)	300 in (mm)	in (mm)	in (mm)	in (mm)	150 in (mm)	300 in (mm)	150 in (mm)	300 in (mm)	150 in (mm)	300 in (mm)	150 in (mm)	300 in (mm)	in (mm)	in (mm)	in (mm)	in (mm)	in (mm)	in (mm)	in (mm)		
1/2 (15)	4	5/8 (16)	2 3/8 (60)	-	-	-	4 1/4 (108)	-	3 1/2 (89)	-	2 31/32 (75)	7/16 (11)	-	1 3/8 (35)	7/16 (11.1)	1 1/2 (9)	-	-	-	-	-	-	-	-	-	7 (178)	-	-	-	1/16 (1.5)	-	5 9/16 (135)	
3/4 (20)	4	5/8 (16)	2 3/4 (70)	-	-	-	4 5/8 (117)	-	3 7/8 (98)	-	3 3/32 (79)	7/16 (11)	-	1 11/16 (43)	7/16 (11.1)	1 1/2 (9)	-	-	-	-	-	-	-	-	-	7 (178)	-	-	-	1/16 (1.5)	-	5 7/16 (138)	
1 (25)	4	5/8 (16)	3 1/8 (79)	4	3/4 (19)	3 1/2 (89)	5 (127)	6 1/2 (165)	4 1/4 (108)	4 7/8 (124)	4 (102)	7/16 (11)	1 1/2 (17)	2 1/4 (57)	2 1/2 (16.6)	3/4 (19)	4 17/32 (115)	4 11/32 (115)	2 3/8 (60)	2 1/2 (60)	4 9/16 (116)	4 9/16 (116)	8 (200)	8 (200)	9 (229)	7 1/8 (181)	-	-	1/8 (3.1)	5 7/32 (33)	6 1/4 (159)		
1 1/2 (40)	4	5/8 (16)	3 7/8 (98)	4	7/8 (22)	4 1/2 (114)	6 1/2 (165)	7 1/2 (191)	5 (127)	6 1/8 (156)	4 11/16 (119)	9/16 (14)	1 3/8 (21)	3 (76)	7/8 (22.2)	1 1/2 (21)	5 5/32 (131)	5 5/32 (131)	2 3/8 (60)	2 1/2 (60)	4 9/16 (116)	4 9/16 (116)	8 (200)	8 (200)	12 (305)	7 1/8 (181)	-	-	1/8 (3.1)	6 7/16 (163)	6 13/16 (173)		
2 (50)	4	3/4 (19)	4 3/4 (121)	8	3/4 (19)	5 (127)	7 (178)	8 1/2 (216)	6 (152)	6 1/2 (165)	5 1/2 (140)	5/8 (16)	7/8 (22)	3 3/4 (95)	7/8 (22.2)	2 (24)	5 13/16 (148)	5 13/16 (148)	2 3/8 (60)	2 1/2 (60)	4 9/16 (116)	4 9/16 (116)	8 (200)	8 (200)	20 (508)	7 1/8 (181)	-	-	1/8 (3.1)	7 1/8 (181)	7 1/2 (190)		
3 (80)	4	3/4 (19)	6 (152)	8	7/8 (22)	6 5/8 (170)	8 (203)	11 1/8 (283)	7 1/2 (191)	8 1/4 (210)	6 11/32 (161)	3/4 (19)	2 1/8 (28)	5 (127)	7/8 (22.2)	2 (24)	6 3/4 (171)	6 3/4 (171)	2 11/16 (68)	2 11/16 (68)	4 9/16 (116)	4 9/16 (116)	8 (200)	8 (200)	20 (508)	8 1/8 (206)	-	-	1/8 (3.1)	7 31/32 (202)	8 11/32 (212)		
4 (100)	8	3/4 (19)	7 1/2 (190)	8	7/8 (22)	7 7/8 (200)	9 (229)	12 (305)	9 (229)	10 (254)	7 21/32 (194)	1 5/16 (24)	1 1/4 (32)	6 1/2 (65)	1 13/32 (35.7)	1 3/8 (35)	8 7/8 (226)	8 7/8 (226)	3 1/16 (87)	3 1/16 (87)	11 1/8 (283)	11 1/8 (283)	12 (305)	12 (305)	30 (762)	8 31/16 (223)	-	-	1/8 (3.1)	-	10 9/16 (259)		
6 (150)	8	7/8 (22)	9 1/2 (241)	12	7/8 (22)	10 3/8 (270)	10 1/2 (267)	15 7/8 (403)	11 (279)	12 1/2 (318)	9 23/32 (247)	1 (25)	1 17/16 (36)	8 9/8 (213)	1 13/32 (35.7)	1 7/16 (36)	10 13/16 (275)	10 13/16 (275)	3 1/16 (87)	3 1/16 (87)	11 1/8 (283)	11 1/8 (283)	12 (305)	12 (305)	-	8 31/16 (223)	-	-	1/8 (3.1)	-	-		
8 (200)	8	7/8 (22)	11 3/4 (298)	-	-	-	14 (356)	13 1/2 (343)	-	13 15/16 (354)	1 5/32 (29)	-	10 5/8 (270)	Spline (36)	1 7/16 (36)	-	-	-	-	-	-	-	-	-	-	-	-	-	-	1/8 (3.1)	-	-	
10 (250)	12	1 (25)	14 1/4 (362)	-	-	-	13 (330)	16 (406)	-	17 (432)	1 3/8 (34.5)	-	12 7/16 (316)	3 (76.1)	3 31/64 (100)	2 17/8 (555)	-	-	-	-	-	-	-	-	24 (610)	-	-	19 13/32 (493)	2 11/16 (53.5)	1 11/32 (280.2)	1/8 (3.1)	-	-
12 (300)	12	1 (25)	17 (432)	-	-	-	14 (356)	19 (482)	-	17 7/8 (454)	1 3/8 (34.5)	-	15 (381)	3 (76.1)	4 7/16 (112)	2 21/32 (575)	-	-	-	-	-	-	-	-	24 (610)	-	-	19 13/32 (493)	2 11/16 (53.5)	1 11/32 (301.8)	1/8 (3.1)	-	-

Note: 1. All dimensions are approximate and for illustration purposes only. For exact dimensions request certified dimensional prints.  
 2. The two top holes on each flange on the 6 in (150 mm) and 8 in (200 mm) valves are drilled for studs.  
 \* E Dimension does not include PTFE raised face per ANSI B-16-5

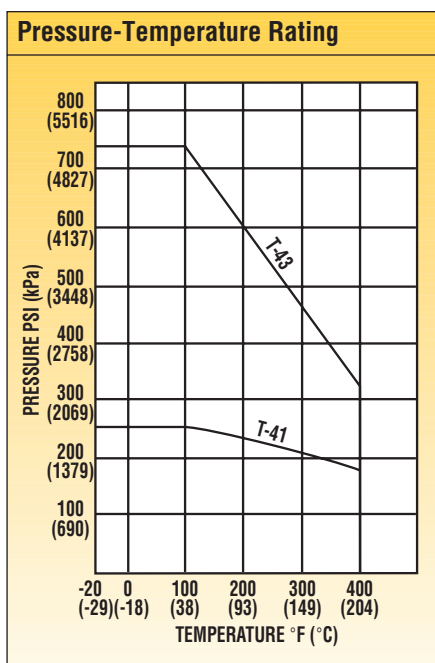

Valve Size in (mm)	Area of Port in <sup>2</sup> (m <sup>2</sup> x 10 <sup>-3</sup> )	% Port Opening Based on ANSI F423-82 PTFE Lined Pipe I.D.	C <sub>v</sub>	Bare Valve Wt. lbs (kg)	
				150#	300#
1/2 (15)	.150 (.097)	76	5.6	5 1/4 (2.3)	—
3/4 (20)	.306 (.197)	69	12	7 3/4 (3.5)	—
1 (25)	.785 (.506)	123	33.9	10 (4.5)	16 1/2 (7.4)
1 1/2 (40)	1.500 (.968)	97	95.4	14 1/2 (6.5)	25 (11.3)
2 (50)	2.550 (1.645)	90	199	21 1/2 (9.7)	27 1/2 (12.4)
3 (80)	4.900 (3.161)	74	343	36 (16.3)	64 (29.0)
4 (100)	9.200 (5.936)	77	813	66 1/4 (30)	135 (61.2)
6 (150)	18.050 (11.646)	66	1105	120 1/4 (54)	200 (90.7)
8 (200)	32.700 (21.098)	67	1424	210 (95.5)	—
10 (250)	36.8 (23.741)	49	2159	345 (156.5)	—
12 (300)	45.6 (29.419)	42	3200	488 (221.4)	—

Consult factory for vacuum rating.

# T-41 Parts List

## 10 in (250 mm) Thru

## 12 in (300 mm)

T-41			
Item No.	Description	Material	Req'd.
1	Body	Ductile Iron/PFA	1
2	Plug	Ductile Iron/PFA	1
3	Cap, Top	Ductile Iron	1
3A	Fasteners, Top Cap	Carbon Steel B7	6
3B	Fasteners, Top Cap	Carbon Steel B7	2
6*	Diaphragm*	PTFE	1
11	Collar, Thrust	Durcomet 100	1
12	Adjuster	Durcomet 100	1
12A	Fasteners, Adjuster	Carbon Steel B7	4
17	Spring, Ground	304 SS	1

\*Recommended spare parts  
**Note:** Body liners are not field replaceable.

### Design Changes

In order to follow Flowserve's commitment to continuous improvement, we reserve the right to change product and performance specifications without notice.

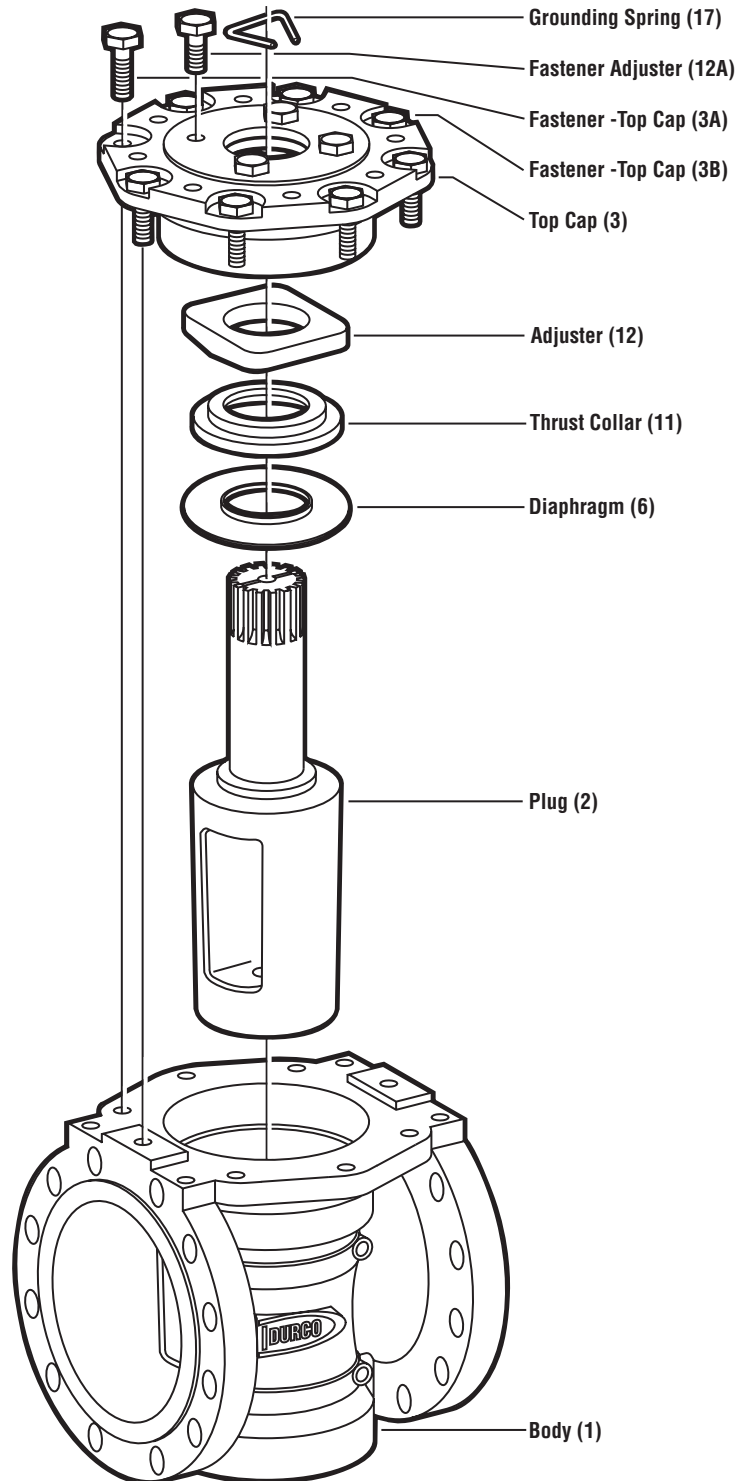

# T-41 and T-43 Parts List

## 1/2 in (15mm) Thru

## 8 in (200 mm)

T-41			
Item No.	Description	Material	Req'd.
1	Body	Ductile Iron/PTFE**	1
2	Plug	Ductile Iron/PFA	1
3	Cap, Top	Ductile Iron	1
3A	Fasteners, Top Cap	Carbon Steel B7	4
6*	Diaphragm*	PTFE	1
11	Collar, Thrust	Durcomet 100	1
12	Adjuster	Durcomet 100	1
12A	Fasteners, Adjuster	Carbon Steel B7	2
17	Spring, Ground	302 SS	1
19	Collar, Stop	Cadmium Plated Carbon Steel	1
19A	Retainer, Collar	302 SS	1
20	Hex Nuts, Top Cap	Carbon Steel 2H	4

T-43			
Item No.	Description	Material	Req'd.
1	Body	Carbon Steel/PTFE	1
2	Plug	Ductile Iron/PFA	1
3	Cap, Top	Durcomet 100	1
3A	Fasteners, Top Cap	Carbon Steel B7	4
6*	Diaphragm*	PTFE	1
11	Collar, Thrust	Durcomet 100	1
12	Adjuster	Durcomet 100	1
12A	Fasteners, Adjuster	Carbon Steel B7	2
17	Spring, Ground	302 SS	1
19	Collar, Stop	Cadmium Plated Carbon Steel	1
19A	Retainer, Collar	302 SS	1
20	Hex Nuts, Top Cap	Carbon Steel 2H	4

\*Recommended spare parts  
 \*\*1/2 in (15 mm) and 3/4 in (20 mm) DCI/PFA  
**Note:** Body liners are not field replaceable.

**New alloy options now available.**  
 Both the plug insert and body armor of the Class 150 and 300 models are available in D4/316SS and other alloys as well as standard DCI. Consult factory for details.

**Design Changes**  
 In order to follow Flowserve's commitment to continuous improvement, we reserve the right to change product and performance specifications without notice.

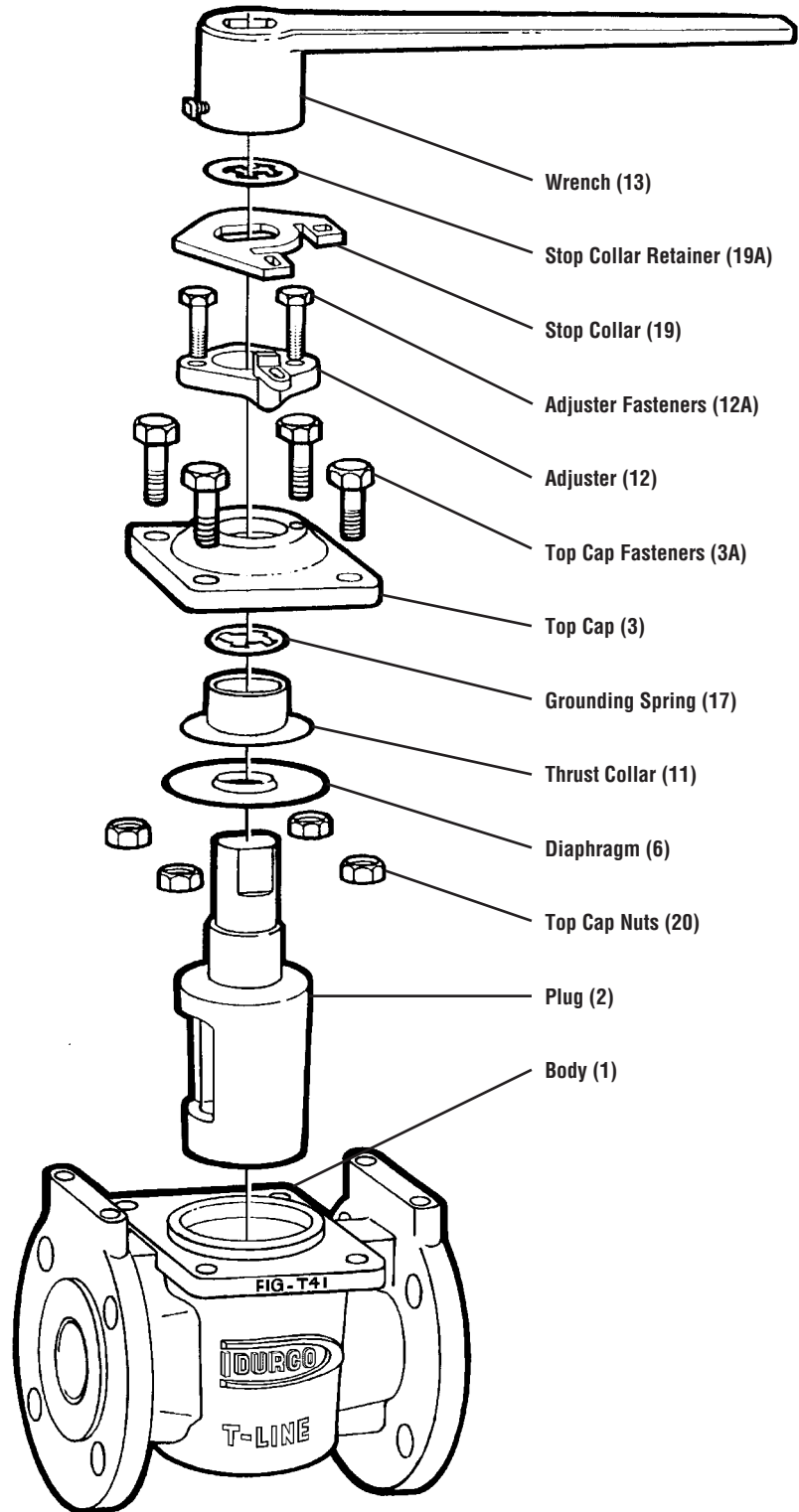



# The world's oldest and largest manufacturer of PTFE lined valves

**N**o one valve is optimum for all service conditions, which is why we offer many options in design and materials. As a result, you have the freedom to choose the best valve for your application.

## Selection, Installation, Operation and Maintenance

Although Flowserve can, and often does, provide general guidelines, it is obviously not possible to provide application specific data and warnings for all conceivable applications. The purchaser/end user must therefore assume the ultimate responsibility for the proper selection, installation, operation and maintenance of the products. Read the appropriate IOM available from Cookeville, TN 38501 before installing, operating or repairing any valve. The purchaser/end user should train its employees and/or contractors in the safe use of the Flowserve products in connection with the purchaser's manufacturing processes.

Contact your trained Flowserve representative for the technical support to satisfy your valving needs.

Flowserve Corporation  
Flow Control Division  
Cookeville, Tennessee 38501  
931 432 4021

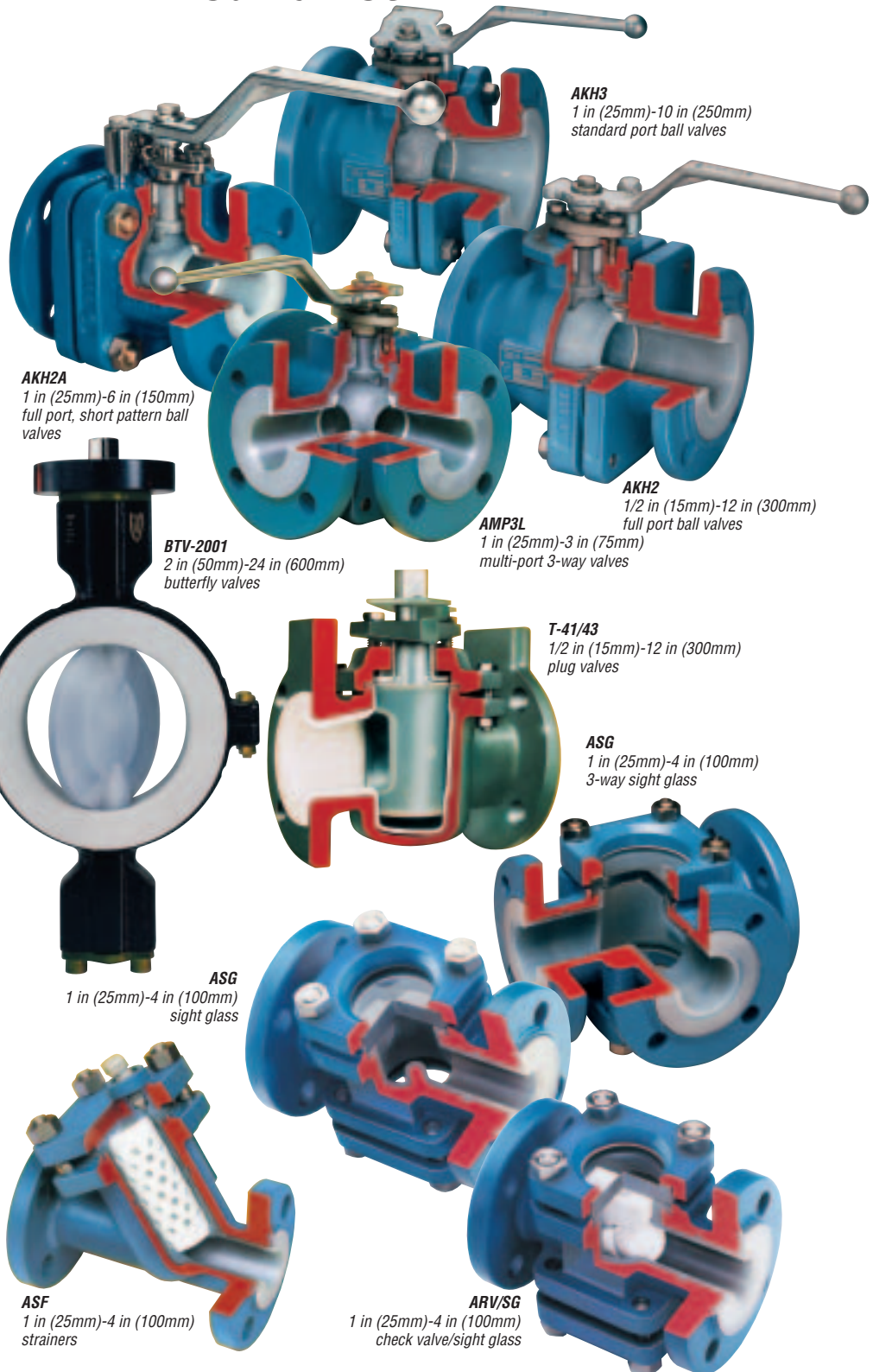

Or Consult Your Local Stocking Distributor

Flowserve Ahaus GmbH  
Von Braun Straße 19a  
D-48683 Ahaus, Germany  
+49 2561 686-0

Flowserve Pte. Ltd.  
Singapore 638824  
Republic of Singapore  
65 862 3332

Printed in U.S.A.  
August 2001  
© Flowserve Corporation